

BROOKFIELD R/S+ RHEOMETER

Operating Instructions

Manual No. **M08-219**

(for serial numbers beginning with "304")



SPECIALISTS IN THE
MEASUREMENT AND
CONTROL OF VISCOSITY

with offices in: Boston • Chicago • London • Stuttgart • Guangzhou

BROOKFIELD ENGINEERING LABORATORIES, INC.
11 Commerce Boulevard, Middleboro, MA 02346 USA
TEL 508-946-6200 or **800-628-8139** (USA excluding MA)
FAX 508-946-6262 INTERNET <http://www.brookfieldengineering.com>

Contents

I. General Description	4
I.1 Use of the Rheometer.....	4
I.2 Measuring Principle	4
II. System Configuration	5
II.1 R/S+ Rheometer	5
II.2 Measuring Geometries.....	7
II.3 Computer System	7
III. Instrument Installation	8
III.1 Mounting the Stand.....	8
III.2 Electrical Connections	9
III.2.1 Temperature Sensor PT100	9
III.2.2 AC Adapter	10
III.2.3 Printer Connection.....	10
III.2.4 Computer Connection	11
III.3 Connecting the Temperature Control Devices	11
III.3.1 Connecting the Water Jacket	11
III.3.2 Connecting the Optional Cone/Plate Attachment	14
III.3.3 Connecting the KE Cooling Device	16
IV. Environment, Handling, Cleaning and Maintenance	17
IV.1 Operating Environment and Storage	17
IV.2 Handling.....	17
IV.3 Cleaning.....	17
IV.4 Maintenance	18
V. Measuring Systems	19
V.1 Measuring Directly in the Sample Container.....	19
V.2 Measurement by Filling the Sample Cup	20
V.3 Measurement with Water Jacket Assembly	21
V.4 Measurement with Cone/Plate or Plate/Plate Measuring System	22
VI. Operation and Menu System	24
VI.1 Keyboard.....	25
VI.2 Menu System of R/S+ Rheometer	27
VI.3 Selecting from Lists	28
VI.4 Input of Numerical Values and Alphanumeric Texts	29
VI.5 Menu Entries (MAIN menu)	30
VI.5.1 MAIN Menu → Run Single	30
VI.5.2 MAIN Menu → Single Measurement	31
VI.5.3 MAIN Menu → Run Program	33

VI.5.4	MAIN Menu → Remote	36
VI.5.5	MAIN Menu → Utilities.....	37
VI.5.7	MAIN Menu → Configuration	37
VI.6	Menu Entries in the Utilities Menu	37
VI.6.1	Utilities → Zero Calibration	37
VI.6.2	Utilities → Edit Program	38
VI.6.3	Utilities → Print Programs	42
VI.6.4	Utilities → Measuring Systems	42
VI.6.5	Utilities → Print Memory	43
VI.6.6	Utilities → Clear Memory	44
VI.6.7	Utilities → Measure Temperature	44
VI.7	Menu Entries of the Configuration Menu	45
VI.7.1	Configuration → Set Output Mode.....	45
VI.7.2	Configuration → Set MeasCount Mode	46
VI.7.3	Configuration → Set MeasCount	46
VI.7.4	Configuration → Set Time/Date	46
VI.7.5	Configuration → Set RS232 Parameters	47
VI.7.6	Configuration → Language	49
VI.7.7	Configuration → Service	49
VI.8	Serial Data Transfer via the RS232 Interface	49
VII.	Measurements.....	51
VII.1	Measuring in Manual Mode.....	51
VII.2	Measuring in with Water Jacket	51
VII.3	Measuring with Cone/Plate Attachment	51
VII.4	Measuring in Remote Mode.....	51
VIII.	Technical Data	53
IX.	Guarantee	55
Appendix A.....		56
A.1	Data Sheets of Standard Measuring Systems	56
A.2	Error Messages.....	58
A.3	Pin Assignment of the Serial Data Cable	61
A.4	Requirements to the AC Power Connecting Cables	61
Appendix B: Calibration Check Procedure.....		63
Appendix C: Warranty and Repair Service.....		71

I. General Description

This chapter has general information about the instrument and operating principle.

I.1 Use of the Rheometer

The R/S+ will measure viscosity of Newtonian and Non-Newtonian materials in controlled shear rate (CSR) or controlled shear stress (CSS) modes. The instrument can measure simple viscosity at a given speed or shear rate, or measure flow properties with a flow curve at shear rates up to $\sim 1,200 \text{ sec}^{-1}$.

In controlled stress mode the instrument can do a direct yield test (stress ramp) and indicate elasticity with creep/recovery tests.

I.2 Measuring Principle

The Rheometer R/S+ is a rotational steady state controlled shear stress rheometer which can be operated in controlled shear rate mode.

Concentric cylinders, measuring cones and plates are available as measuring system. The measuring sample is positioned in measuring gap between the stationary measuring cup and the rotating measuring bob (Searle-principle), respectively between the rotating cone or plate and the stationary lower plate (cone/plate, cone/cone measuring system).

The measuring drive developed for this instrument operates with a high dynamic precision-drive- system with optical encoder without gearing and without mechanical force transducers.

The R/S+ measuring drive can operate at a pre-set of speed (shear rate) or pre-set of torque (shear stress). Measurements may be made in manual mode (without PC) or under PC control with software RHEO3000. Note that creep measurements require computer system with software RHEO3000

Both CSR and CSS measurements can be carried out manually (without PC support) or with a computer system and software RHEO3000.

II. System Configuration

The R/S+ Rheometer system consists of:

- Electronic unit and measuring drive integrated in one housing
- Stand with working surface
- AC Adapter

Available Accessories:

- Start-up and training service
- Printer
- **Coaxial cylinder measuring system (see Appendix A)***
- **Temperature measuring sensor Pt100***
- Water jacket assembly
- Bath/Circulator
- Computer system
- Software RHEO3000
- Vane spindles

***The accessories in bold print are necessary for a minimal configuration.**

II.1 R/S+ Rheometer

The Rheometer electronics with measuring drive are built-in in one housing.

Instrument features include:

- Digital control of rotational speed and torque.
- Automatic adjustment of control parameters during measurement.
- Direct indication of measured and calculated values of speed/ shear rate, torque/shear stress, viscosity, temperature, and time.
- Data storage (measured values)
- Data output to a printer (parallel).
- User support with LCD and keyboard
- Built-in system interface with serial standard interface (RS232-C) for connection to a computer or other serial data-logger.
- Printing and serial data-transmission during the test

The R/S+ Rheometer can either be operated manually using the keyboard at the front panel or it can be operated under computer control. The R/S+ Rheometer is supplied with direct current by the AC Adapter.

R/S+ Rheometer

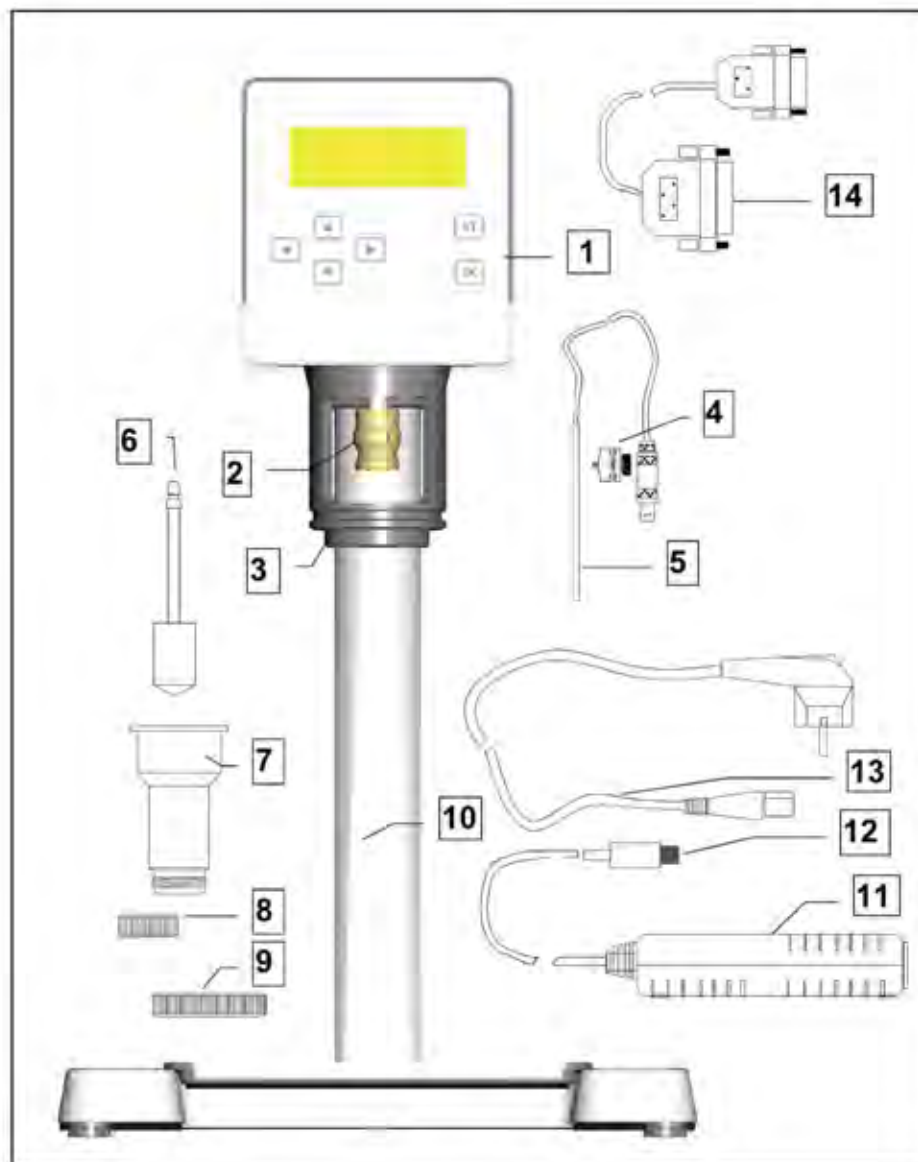

- 1 R/S-CPS Rheometer
- 2 Measuring Bob Coupling
- 3 Mounting Flange
- 4 Pt100 Clamp Fixture (accessory)
- 5 Pt100 (temperature probe accessory)
- 6 Standard Measuring Bob (accessory)
- 7 Standard Measuring Cup (accessory)
- 8 Measuring Cup Bottom or Thread Protection (accessory)
- 9 Measuring Cup Screw Fitting
- 10 Stand
- 11 AC Adapter
- 12 Direct Current Plug (to rheometer head)
- 13 AC Power Cable
- 14 RS232 Cable (accessory)

Fig. II-1: Configuration of the R/S+ Rheometer

II.2 Measuring Geometries (Spindles or Bobs with Sample Cups)

Measuring devices are not included in base instrument price of Rheometer R/S+ and must be ordered separately.

Measuring devices (cups and bobs) optionally supplied:

- coaxial standard measuring systems for R/S+ (see Appendix A) with and without built-in temperature sensor Pt100
- Water Jacket Assembly for use of cylinder measuring system in temperature range -10°C to +180°C

II.3 Computer System

The computer system is optional and provides automatic measuring, data plots, printing (full reports or data plots) as well as analysis of results and quality control charts.

The recommended computer system consists of:

- IBM-compatible PC with the following minimal system requirements:
 - CPU / 1 GHz minimum
 - 512 MB RAM (main memory)
 - 500 MB free hard disk capacity
- operating system Microsoft Windows 2000™, Windows XP™ or Vista™
 - mouse and keyboard
 - VGA graphic card and monitor
 - 1 free serial interface
- Printer
- User Software RHEO3000

III. Instrument Installation

Setting up the R/S+ and taking first measurements:

- How to mount the Rheometer R/S+,
- Electric connections
- Installation of accessories such as bath circulator and measuring system
- Hose connections

III.1 Mounting the Stand

The stand consists of:

- the stand base plate
- the stand column with Rheometer

Hex-nut wrench size 6 and bolt DIN 912 M8x40 are supplied for mounting.

The stand column is connected to the stand base plate with a bolt. The proper orientation of the column is set with a pin in the bottom of the column which fits into a hole on the stand base.

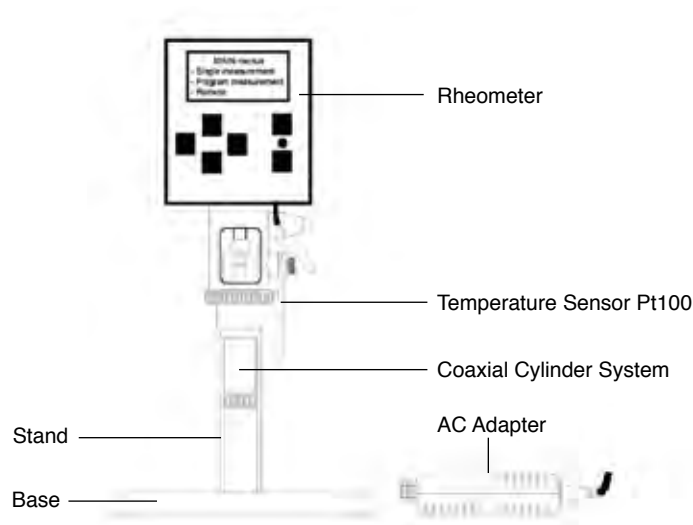
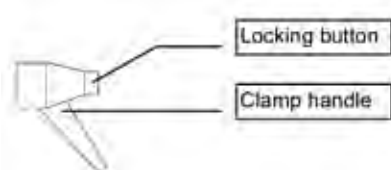

Fig. III-1.: Rheometer R/S+ (minimum configuration)

Hints for height adjustment of the stand:



To change the height adjustment of the stand you release the clamp handle and move the stand to the desired height.

Caution: Hold the Rheometer as you release the clamp handle! You can press the locking button to change the clamp handle position without screwing/unscrewing the thread. After adjustment of the height screw tighten clamp handle thread.

Fig. III-2.: Stand Height Adjustment Hints

III.2 Electrical Connections

Connections for the electrical components of the R/S+ Rheometer are located on the back of the instrument.

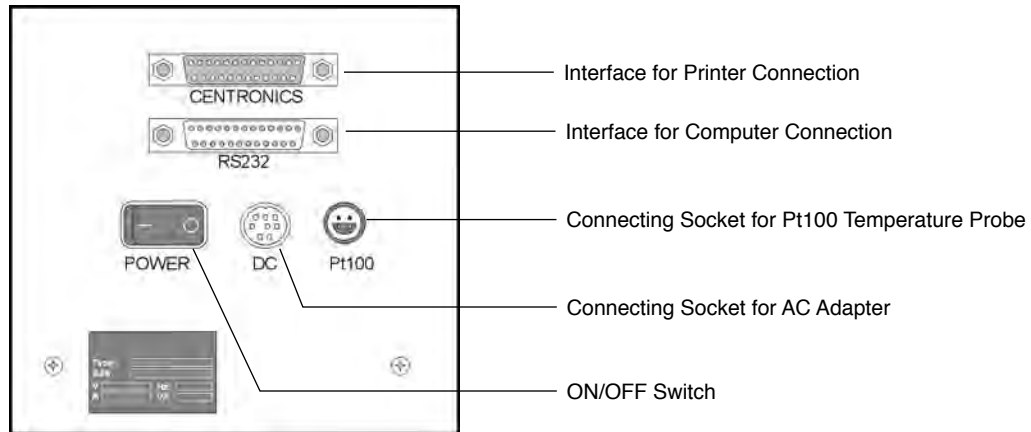
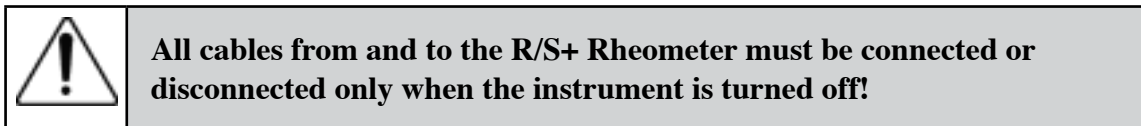

Fig. III-3: Operating and connecting elements at the back side of the measuring head



III.2.1 Temperature Sensor PT100

The connecting cable for the temperature sensor Pt100 (100 ohm DIN alpha RTD) is inserted into connector labeled “Pt100” at the back of the Rheometer.

If you use standard cylindric measuring cups (CC8, CC14 etc.), put the Pt100 into the mounting clamp and fix it parallel to the measuring system at mounting flange of the Rheometer.

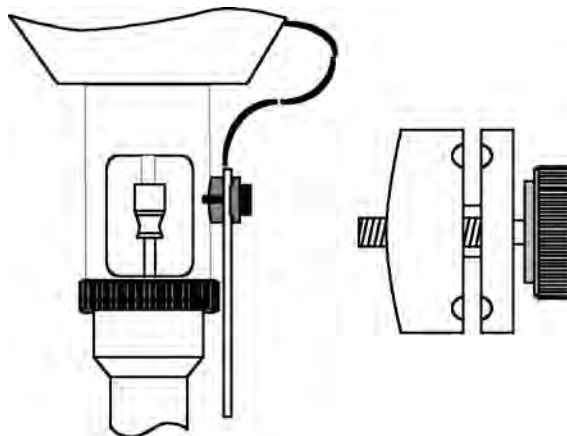

Fig. III-4: Pt100 connection and mounting

Insert the plug of Pt100 connector labeled “Pt100” on the back of the Rheometer.

As the viscosity is a function of the temperature, the temperature should be measured, preferably in the test fluid. For this purpose, the standard measuring systems 8 mm to 40 mm DIN can be equipped with a Pt100 in measuring cup bottom (only when the water jacket is used) If you use a measuring system with built-in Pt100, this is where you will insert the cable VK-Pt/RC.

III.2.2 AC Adapter

Only the AC adapter originally supplied by Brookfield should be used to power the R/S+ Rheometer. Do not use a power supply other than the AC adapter delivered by Brookfield for the R/S+ Rheometer.



Connect the AC adapter using a grounded plug to avoid electric shock or damage of the system components.

Connecting the AC adapter:

- Switch the R/S+ Rheometer off (“POWER” at the back side of the instrument).
- Connect the RS+ power cord into the AC adapter.
- Insert the socket of the DC cable into the connector “DC” at the back side of the R/S+ Rheometer.
- Plug the power cable into a grounded main socket.
- Turn the R/S+ Rheometer on.

Do not leave the power supply plugged when the cable to the rheometer is unplugged!

Before disconnecting Rheometer from AC supply be sure that the instrument is switched off.

III.2.3 Printer Connection

Printer can be connected directly to the interface connector of the Rheometer when measuring without PC control. You must preset “Printer” as output device to print the measuring values during measurement (see Chapter VI). The printer should have a centronics parallel interface. USB printers are not supported.

- Turn off the Rheometer R/S+ with the AC switch “POWER” at the back of the R/S+.
- Insert the printer connecting cable into the “PRINTER” port on back of the instrument.
- Turn the R/S+ Rheometer on.

Standard printer cable can be used as printer connecting cable. This cable is supplied with the printer in most cases. To print data values from the Rheometer R/S+, any (parallel) printer which can operate in ASCII character mode may be used.

III.2.4 Computer Connection

If the Rheometer R/S+ has to be used in “REMOTE” mode with PC (RHEO3000 program package) or with serial data-terminal for data logging, the RS232 cable is connected to the 25 pin port labeled “RS232” on the back of the instrument.

- Turn the R/S+ Rheometer off with the “POWER” switch at the back of the instrument.
- Turn the computer system off.
- Connect the PC data cable to the 25 pin port labelled “RS232” on the back of the R/S+ Rheometer.
- Connect the PC data cable to the port labelled “RS232/Peltier” on the back of the P-TS control unit.
- Connect the other end of PC data cable with a free RS232 serial port (e.g. “COM2”) on your computer.
- Turn the R/S+ Rheometer and your computer system on again.

You must use the computer cable supplied by Brookfield - other cables will not work!

III.3 Connecting of Temperature Controlled Measuring Devices

This chapter discusses how to connect to following temperature control devices:

- **Water Jacket Assembly** for use of cylinder measuring system in the temperature range of -10°C to $+90^{\circ}\text{C}$ (liquid’s temperature control)
- **Cooling Device KE** in conjunction with FTK/R/S+ temperature control device or CONE/PLATE ATTACHMENT measuring device to raise the temperature range up to -20°C to $+180^{\circ}\text{C}$

III.3.1 Connecting the Water Jacket

As temperature control device is available optionally:

- **Water jacket FTKY**

for use of cylinder measuring system in the temperature range -10°C to $+90^{\circ}\text{C}$.



The temperature water jacket should be used only in the temperature range -10°C to $+90^{\circ}\text{C}$ unless the KE cooling device is installed, in which case, the temperature range is -20°C to $+180^{\circ}\text{C}$!

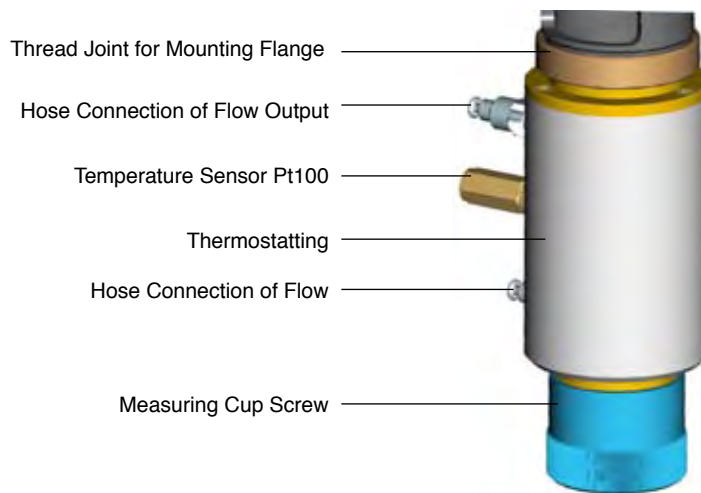

Fig. III-5: Water Jacket Assembly

Mounting the Water Jacket Assembly:

- Turn off the R/S+ with the mains switch “POWER” at the back of the instrument.
- When using cooling device KE mount cooling device first (see Chapter 3.3.3)
- Set the jacket from below on the mounting flange of Rheometer R/S+ and tighten the thread.
- Fix the hoses of liquid circulation thermostat at the jacket.
- Connect the jacket’s built-in Pt100 cable with the connector “Pt100” at the back of the instrument of the R/S+ Rheometer.

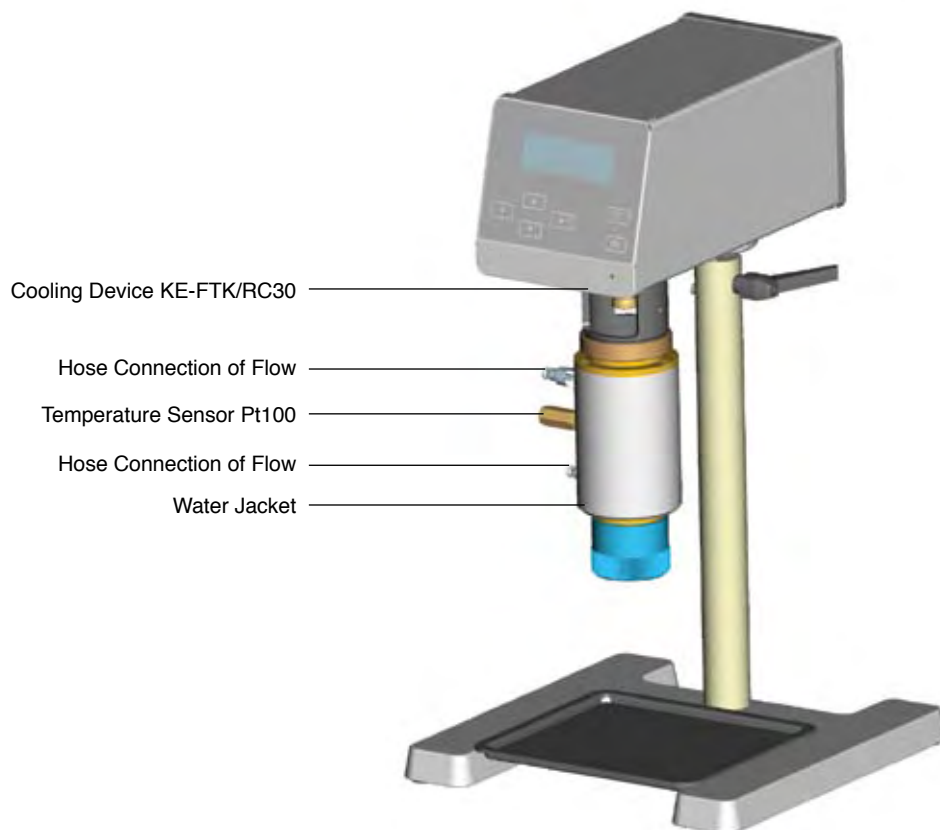

Fig. III-6: Operation with FTK/RS+ and Cooling Device KE

Bath/Circulator Connection to the Water Jacket

Hose connections are necessary to connect the bath to the R/S+ water jacket.

The hoses are connected to quick fitting couplings on the jacket assembly (below: inlet; above: outlet). The coupling has a female part which is put into the tubing, and a male part built into the jacket assembly. To connect the two pull back on the female section slide ring and put the connector onto the jacket (male) connector, releasing the slide ring.



Water jacket without cooling device KE must only be used in the temperature range -10°C to +90°C!

The temperature control device FTK/R/S+ can be used in the temperature range -20°C to +180°C when used with the optional KE cooler (for tap water cooling of the Rheometer bearings)

It is recommended urgently to preset at liquid circulation thermostat the upper temperature limitation: when using water at 90°C and when using oil at 180°C (only with Cooling device KE).

As thermostatic liquids are usually used:

-10°C to +90°C	Water (de-ionized) - Glycol Mixture
-20°C to +180°C	Thermostat Oil

Suitable bath fluids can be ordered from **BROOKFIELD**.



During measurements in the temperature range -10°C and above +90°C, the water jacket may be put into operation only if the cooling liquid flows through the KE cooling attachment in order to prevent overheat of the measuring sensor.

III.3.2 Connecting the Optional Cone/Plate Attachment

- Turn off the R/S+ with the mains switch “POWER”.
- When using KE cooling device, mount the cooling device first (see Section III.3.3)
- Set the “CONE/PLATE ATTACHMENT” from below on the mounting flange and tighten the thread. Check that before tightening the guide pin of the measuring device (see Fig. III.7) must be in the slot of the R/S+ mounting flange!
- Fix the hoses of liquid circulation thermostat at the “CONE/PLATE ATTACHMENT”.
- Insert the temperature sensor cable of “CONE/PLATE ATTACHMENT” in the plug socket “Pt100” at the back of the instrument of the Rheometer R/S+.
- For mounting cone/plate or plate/plate measuring systems to measuring device refer to Section 5.

Bath/Circulator Connection to the Cone/Plate Attachment

The hoses are connected to quick fitting couplings on the cone/plate assembly (below: inlet; above: outlet). The coupling has a female part which is put into the tubing, and a male part built into the jacket assembly. To connect the two pull back on the female section slide ring and put the connector onto the jacket (male) connector, releasing the slide ring.



The measuring device CONE/PLATE ATTACHMENT without cooling device KE COOLING ATTACHMENT must only be used in the temperature range -10°C to +90°C.

We suggest that when using a bath/circulator the high limit cut-off be at 90°C or 180°C depending on liquid (water or bath oil).

As thermostatic liquids are usually used:

-10°C to +90°C	Water (de-ionized) - Glycol Mixture
-20°C to +180°C	Bath Oil

Suitable bath fluids can be ordered from **BROOKFIELD**.

	During measurements in the temperature range below -10°C and above +90°C, the measuring device CONE/PLATE ATTACHMENT may be put into operation only if the cooling liquid flows through the the KE COOLING ATTACHMENT in order to prevent overheat of the measuring sensor.
---	--

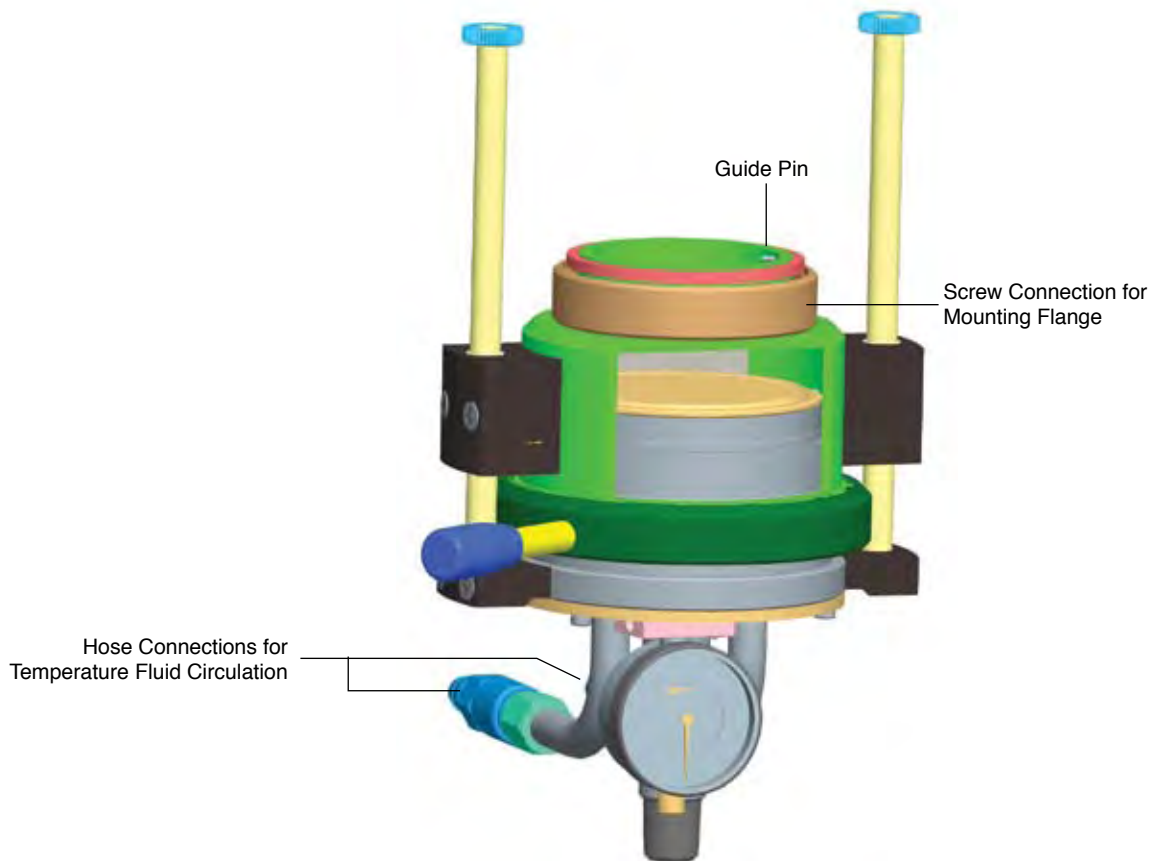

Fig. III-7: Measuring Device CONE/PLATE ATTACHMENT for cone/plate and plate/plate systems

III.3.3 Connecting the KE Cooling Device

The optionally supplied cooling device KE COOLING ATTACHMENT must be used where test temperature is to be below -10°C or above 90°C . When using KE COOLING ATTACHMENT the temperature range can be expanded up to -20°C to $+180^{\circ}\text{C}$.

The cooling liquid flows through the cooling channel of the cooling device and cools the instrument bearings/electronic parts.

Connecting

- Turn off the R/S+ with the mains switch “POWER”.
- Lift the KE COOLING ATTACHMENT from below to the R/S+ Rheometer and tighten the thread.
- Fix the hoses of the cooling loop at the KE COOLING ATTACHMENT (see below “Cooling water connection to cooling device KE”).

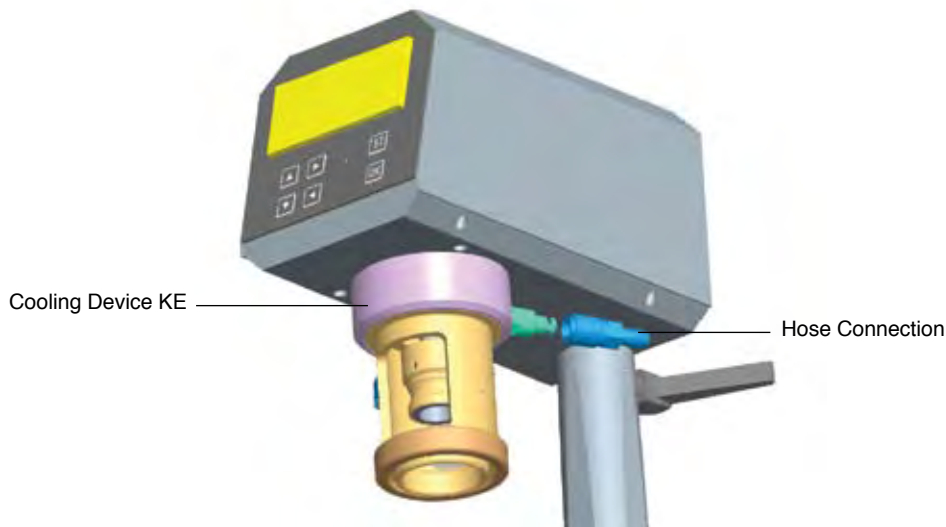

Fig. III-8: Cooling Device KE

- The hoses of cooling circulation loop are connected with by quick fitting coupling with the cooling device “KE”.



During measurements in the temperature range below -10°C and above $+90^{\circ}\text{C}$, the cooling device KE must be used!

IV. Environment, Handling, Cleaning and Maintenance

This chapter covers the environment, handling, cleaning and maintenance of your RS+ Rheometer.

IV.1 Operating Environment and Storage

Find a comfortable, convenient work place for the installation of the R/S+ Rheometer. There should be enough room to place the Rheometer, the measuring systems, the measuring substances and the peripheral devices (e.g. printer, computer and bath/circulator). You need a grounded AC plug to operate the R/S+ Rheometer. You also need an additional plug for the connection of each peripheral device. Your operating environment and the place where you store the R/S+ Rheometer should not be extremely hot, extremely cold or extremely moist. Places with strong temperature and air humidity fluctuation should also be avoided. Be sure that the R/S+ Rheometer is not exposed to the following:

- heavy dirt or dust
- direct sun radiation
- objects that emit strong heat (e.g. heating radiators)
- objects with a strong electromagnetic field (e.g. loudspeakers, motors etc.)
- liquids or corrosive chemicals

IV.2 Handling

The R/S+ Rheometer is designed to work under light bumps or with vibration. You must, however, avoid dropping it or exposing it to heavy shock!



Never lift your RS+ Rheometer at the measuring bob coupling or a built-in measuring bob. Avoid everything that might impair the free and concentric rotation of the measuring element coupling (e.g. shock).

The rheometer motor will automatically turn off if maximum torque (50 mNm) is exceeded.

IV.3 Cleaning

The paint coat of the R/S+ Rheometer resists attack by most usual solvents and weak acids. Use a dry, clean, soft and nap-free piece of cloth to clean the housing. Use neutral detergent liquids and a piece of soft cloth in case of heavy soiling of the housing.



Do not use chemical products such as strong solvents or strong acids to clean the housing, especially the operating field with the foil keyboard.

Make sure no liquid penetrates into the housing (e.g. through the instrument connecting sockets) and into the bearings of the measuring drive.

IV.4 Maintenance

The R/S+ Rheometer system is designed for long-term operation. Should the instrument require repair, contact Brookfield or your Brookfield dealer.



Work on control electronics, all accessories, the measuring drive as well as with the AC Adapter and all electric circuits and connections may only be done by authorized service personnel!

Measurement accuracy can be checked by the customer at any time. We recommend that measurement be done with standard oils (mineral oil or silicone) such as Brookfield fluid 1000 CPS ($\sim 1.0 \text{ Pa}\cdot\text{s}$)

You must use temperature control (i.e., water jacket and bath) and we recommend the 40 mm cup and bob.

Select the appropriate measuring system.

Carry out measurements at the following preset M (% torque): 250%, 500% and 950%

Read viscosities from the display.

In case of instrument failure (or severe deviation from the preset value), contact Brookfield or your Brookfield Dealer.

V. Measuring Systems

This chapter covers the use of the measurement system (cups and bobs or spindles and sample chambers). The following measuring systems are available:

- a) Standard immersion measuring systems with bob diameters from 8mm to 40 mm and double gap for measurement without temperature water jacket and bath/circulator consisting of:
 - measuring cup
 - measuring cup bottom
 - measuring bob
- b) Standard measuring systems with bob diameters from 8mm to 40 mm and double gap for measurement with temperature control device FTK/R/S+ consists of:
 - measuring cup
 - bottom cap
 - measuring bobs
 - optionally Pt100 temperature sensor in measuring cup bottom or water jacket assembly
- c) Disposable measuring system for bob diameters from 8mm to 40 mm for measurement with temperature control consisting of:
 - measuring cup mounting (holder for disposable disposable cups)
 - disposable measuring cup (aluminium)
 - measuring cup ejector (aka pusher)
 - measuring bob
- d) Cone/plate measuring system for 25 mm and 50 mm cones for measurement with measuring device CONE/PLATE ATTACHMENT consisting of:
 - measuring cone
- e) Plate/plate measuring system for 25 and 50 mm plate for measurement with measuring device CONE/PLATE ATTACHMENT consisting of:
 - measuring plate (P25/30, P50/30) depending on measuring system

Please select a suitable measuring system for the desired measuring range to carry out measurements. (for details of measuring systems ranges refer to Appendix A).

V.1 Measuring Directly in the Sample Container

You may immerse the measurement system directly into a container of sample by removing the cap on the bottom of the immersion cups.

When using the measuring system double gap bob do not damage the “O” ring which forms the seal between the inner and outer parts of the sample cup. To clean the inner section is

removed by unscrewing the (stainless steel) ring at the bottom and then GENTLY pushing the inner section out the bottom of the outer section. Take care not to damage or stretch the O-ring seal during removal! Insert the inner part again and screw the measuring system.

- Lift the coupling sleeve of the measuring bob coupling (ring visible).
- Insert carefully the measuring bob into the measuring bob coupling. Pay attention to insert the measuring bob shaft into the measuring bob coupling without impact.
- Lower the coupling sleeve of the measuring bob coupling (ring covered).
- Fasten the measuring cup at the measuring cup mounting flange with the measuring cup thread.
- Immerse the measuring cup into the substance up to the ring mark or up to the point where diameter of measuring cup increases.

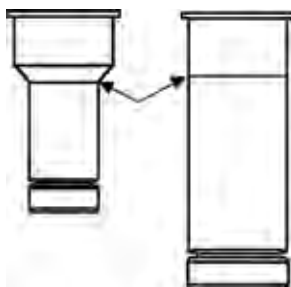

Fig. V-1: Depth of immersion

Do not get sample in or onto the measuring bob coupling, or measuring drive or electronics.

After the end of measurement, unscrew the measuring cup thread and remove measuring cup. Then open the measuring bob coupling and remove the measuring bob.

Clean measuring cup and measuring bob carefully. Do not use hard objects, always prevent scratches! Store measuring bobs on a soft pad.

V.2 Measurement by Filling the Sample Cup

Fill the measuring cup with substance (sample filling quantity see Appendix A1 “Data sheets of the standard measuring system”). Avoid air bubbles when filling in the sample as they can (badly) effect the repeatability of the test!

Place the measuring bob in measuring cup. Lift the coupling sleeve of the measuring bob coupling (ring visible). Insert the complete measuring system from below into the measuring cup mounting flange and screw tight using the measuring cup thread. Insert the measuring bob shaft into the measuring bob coupling without impact. Now insert the measuring bob shaft completely into the measuring bob coupling and move down the coupling sleeve of the measuring bob coupling (ring is covered).

If you want to measure with temperature control, the bath/circulator must be pre-set at the de-

sired temperature and you should wait until bath liquid and sample are at test temperature.

Now the measurement can be carried out.

To remove the measuring system after the measurement first open the measuring bob coupling and then unscrew the measuring cup thread.



If you have carried out measurements at very high or very low temperatures, please take care as some surfaces can become very hot or very cold. Before removing the measuring system, please wait until the system-surface temperature equalized to nearly room temperature to avoid injury.



When unscrewing the measuring cup, you must hold the measuring system tightly with one hand to avoid dropping the cup and bob!

Clean the measuring cup and measuring bob carefully without using hard objects to avoid scratches! Store the measuring bobs on a soft pad.

V.3 Measurement with Water Jacket Assembly

In case of disposable measuring systems insert the disposable measuring cup into the measuring cup mounting. Fill the measuring cup with substance (sample filling quantity see Appendix A1 “Data sheets of the standard measuring system”).

Avoid air bubbles when filling in the sample as they can (badly) effect the repeatability of the test!

Place the measuring bob in measuring cup. Lift the coupling sleeve of the measuring bob coupling (ring visible). Insert the complete measuring system from below into the temperature control device and screw tight using the measuring cup screw. Insert the measuring bob shaft into the measuring bob coupling without impact. Now insert the measuring bob shaft completely into the measuring bob coupling and move down the coupling sleeve of the measuring bob coupling (ring is covered).

The water bath must now be pre-set at the desired temperature and you should wait till the test temperature is achieved (e.g. temperature measurements through the Pt100 menu point “Utilities->Meas.-Temperature” see Section 6). Now the test may be run.

To remove the measuring system after the measurement first open the measuring bob coupling and then unscrew the measuring cup screw of temperature control device.



If you have carried out measurements at very high or very low temperatures, please take care as some surfaces can become very hot or very cold. Before removing the measuring system, please wait until the system-surface temperature equalized to nearly room temperature to avoid injury.



When unscrewing the measuring cup, you must hold the measuring system tightly with one hand to avoid dropping the cup and bob!

When using disposable measuring cups, eject the disposable measuring cup with the pusher.

Clean the measuring bob carefully, do not use hard objects to prevent scratches!
Store measuring bobs on a soft pad.

V.4 Measurement with Cone/Plate or Plate/Plate Measuring Systems

Installing and adjusting of the measuring cone or measuring plate

To install any measuring cone or plate the bayonet lock must be released (position “opened”) and the lower plane-table must be displaced down.



During release of the bayonet lock the measuring device has to be hold tight at the lower part. Otherwise the plane-table is falling down on its own.

Unlock the inner hexagon screw on shaft of the spindle (e.g. cone C50-1/30, plate P25/30 and others) to be inserted. Correct the length to the minimum, which can be adjusted, and tighten the shaft at this position by moderate forces.

Lift the coupling sleeve (red ring mark visible). Insert the measuring spindle (cone or plate) from below into measuring coupling. Move down the coupling sleeve (ring covered) in order to fix the spindle.

Turn the adjusting screw on plane-table down to the lowest position. Remove the plane-table in top end position again, and fix it by bayonet lock (position “closed”).

The actual distance between spindle and plane-table has to be reduced to approx. 1 mm by turning upwards the adjusting screw. Stop the upwards movement at a reasonable screw mark “0” on scale of adjustment screw.

After this the dial indicator should be also set to mark “0” for distance control. Unlock the spindle shaft again, which brings the spindle in touching position on the plane-table. Lock the hexagon screw to fix the shaft.

The plane-table must now be lowered by 0.5 mm with adjustment screw (equivalent to one revolution). From the lower position turn upwards again, but stop at screw mark “5” (50 μm), which corresponds for the correct cone distance for measurements. Other distances, which are required using a measuring plate (e.g. P50/30), have to be chosen by the same procedure – start always one revolution (0.5 mm) below final measuring position.

Measurement

Open the bayonet lock and lower the plane-table. Apply the desired measuring substance. Lift up the plane-table and fix the bayonet lock. Now, the measurement can start.



Remove excess sample from around the cone or plate before starting the measurement.

If temperature control is required, a bath/circulator is connected. The bath must be set at the desired temperature, and you should wait until the bath has reached test temperature.

VI. Operation and Menu System

The following section summarizes the operation and the menu system of the R/S+ Rheometer for both manual and PC-controlled measurement.

Menu prompts for the R/S+ Rheometer are available in the following languages:

- English
- German

The language is selected via the menu level **Configuration**→**Language** (if English is active) or **Konfiguration**→**Sprache** (if German is active). For more details on language selection, see *Chapter VI.7.6*.

After applying power to the R/S+ Rheometer, the LCD displays the following information for a few seconds:

- name of the Rheometer
- software version of the firmware installed in the instrument
- serial number of the instrument
- date and time

Example:

```
R/S+ Rheometer
Ver.: 9.00    #xxxxxxx
27.01.08    15.12
©Brookfield Engineering
```

About five seconds later, the instrument checks the voltage of the power supply. The displayed voltage should be in the range of 14.9 to 16V. If the voltage is outside this range, contact Brookfield or your local Brookfield dealer.

Example:

```
Voltage Check:
VCC:15.25 V
```

This message is displayed for about 3 seconds and then the MAIN menu is displayed. A brief summary of the Rheometer keyboard and the corresponding Rheometer functions may be helpful before you get to the complete description of the menu in *Section VI.4*.

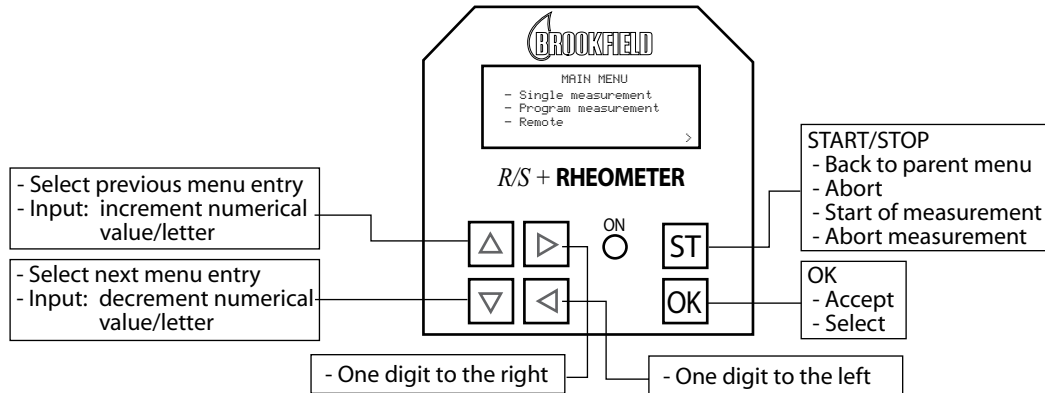

VI.1 Keyboard



All user inputs are made using the six keys located below the LCD. Some of the keys are of multiple use, i.e. their function depends on the current operation. The following table shows the keyboard functions in detail.

Keypad layout of the R/S+ Rheometer

Key	Operation	Function of Key	Example
	<ol style="list-style-type: none"> 1) Menu 2) Input of numerical values 3) Selection from list 	<ol style="list-style-type: none"> 1) Goto previous menu entry (above active one) 2) Increment 3) List entry above active entry (previous) 	<ol style="list-style-type: none"> 1) Utilities → Remote 2) 8 → 9 A → B 3) Select meas. system CC25/30 → CC37/30
	<ol style="list-style-type: none"> 1) Menu 2) Input of numerical values 3) Selection from list 	<ol style="list-style-type: none"> 1) Goto next menu entry (below active one) 2) Decrement 3) List entry below active entry (next) 	<ol style="list-style-type: none"> 1) Remote → Utilities 2) 5 → 4 F → G 3) Select meas. system CC37/30 → CC25/30
	<ol style="list-style-type: none"> 1) Menu 2) Input of numerical values 3) Selection from list 	<ol style="list-style-type: none"> 1) Goto previous menu entry (above active one) 2) One digit to the right 3) List entry above active entry (previous) 	<ol style="list-style-type: none"> 1) Utilities → Remote 2) 100.00 → 100.00 Test → Test 3) Select meas. system CC25/30 → CC37/30

Key	Operation	Function of Key	Example
	1) Menu 2) Input of numerical values 3) Selection from list	1) Goto next menu entry (below active one) 2) One digit to the left 3) List entry below active entry (next)	1) Remote → Utilities 2) <u>1</u> 00.00 → 100.0 <u>0</u> Test → Test 3) Select meas. system CC25/30 → CC37/30
	1) Menu 2) Input of numerical values 3) Selection from list 4) Measurement 5) Remote operation	1) Return to parent menu (turn page downward) 2) Break input (only if possible) 3) Break selection (only if possible) 4) Start and Break measurement 5) Break measurement back to main menu	1) Utilities → Main 3) Select meas. system → back to menu 4) Break when measuring
	1) Menu 2) Input of numerical values 3) Selection from list	1) Select active menu level (open sub-menu) 2) End of input/acceptance 3) Select active list element	

VI.2 Menu System of R/S+ Rheometer

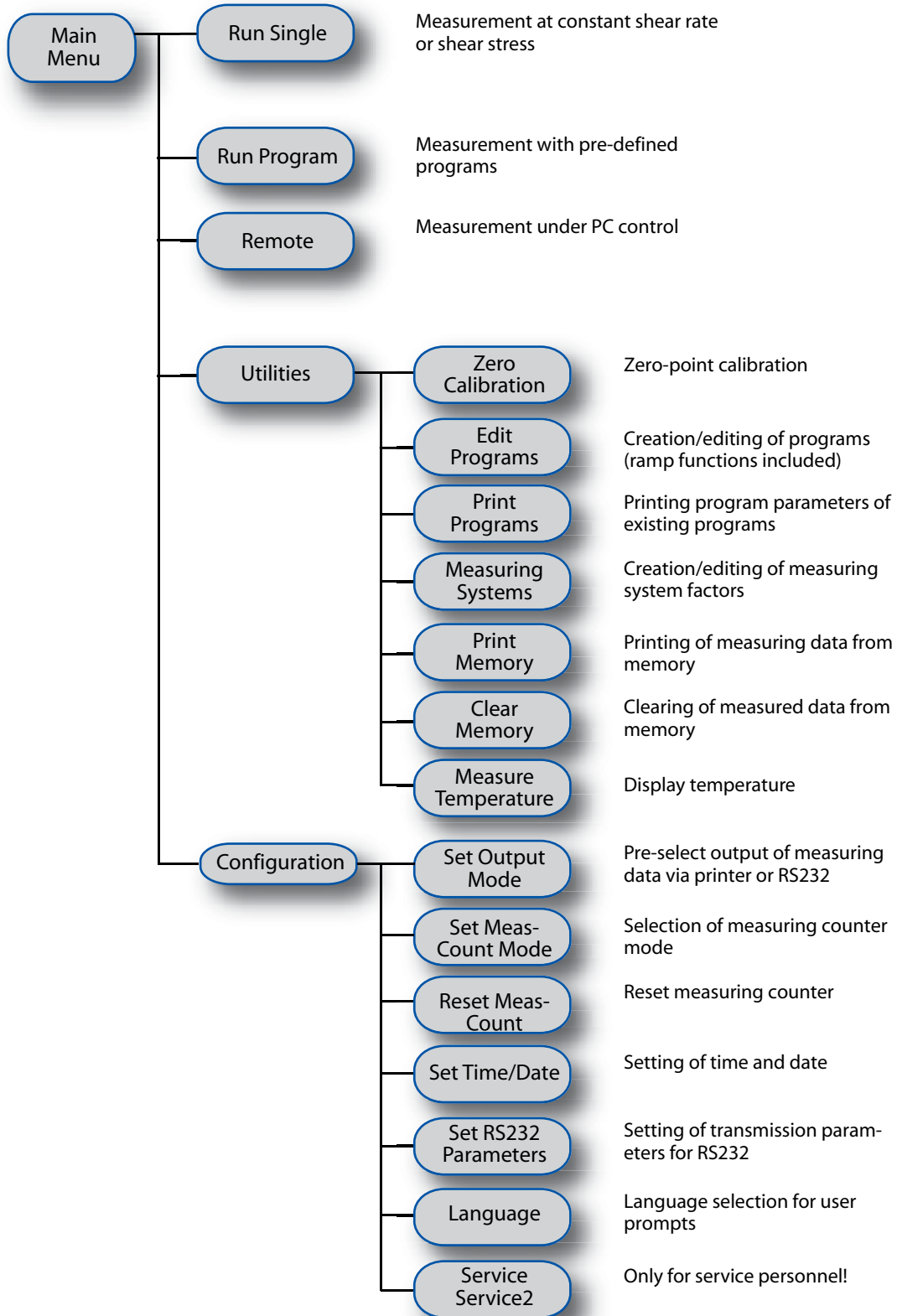



Menu Handling

Since the LCD of the R/S+ Rheometer cannot show all menu items simultaneously, only three entries are displayed on the menu at a time. Arrows (>) on the right side of the display indicate that there are more menu entries. The arrow on the 2nd line indicates there are more menu entries above and the arrow on the 4th line indicates more menu entries below.

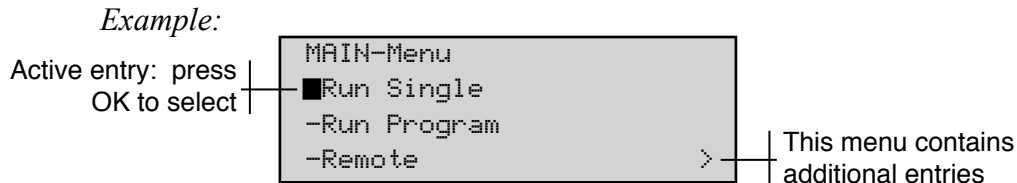
The currently active (but not yet selected) entry is marked by a blinking field (cursor) on the left side of the LCD.



Using the  and  keys, you can move the cursor up and down in the menu until the desired menu entry is reached.

Note: If there are more menu entries in the menu when you have reached the end of the display, the next part of menu will be opened automatically (scrolling).



You can “start” the menu entry by pressing the  key, as well as open the related sub-menu.



If you are in a submenu and wish to return to the upper menu, press the  key.

VI.3 Selecting from Lists

The same keyboard and display functions that are in the menu apply if you have to select a pre-existing entry from a list. Selection from a list is required for the following:

- Select a measuring system for measurement, e.g. in “Run Single” or “Edit Program”
- Select pre-set values for measurement, e.g. in “Run Single” or “Edit Program”
- Select a program or a measuring system you want to edit in “Edit Program” and “Measuring Systems”
- Answer a request “YES” ↔ “NO”.
- Select the program to be started in “Program Measurement”

The  and  keys move the cursor up and down the list.

The  key selects the entry,  Breaks the selection from the list (only if possible).

Example:

```
Select Meas.system:
1) DG DIN      >
2) CC40
3) CC25      >
```

VI.4 Input of Numerical Values and Alphanumeric Texts

Most user defined entries are numbers. User defined values such as the Start and End values of a ramp, number of measuring points, factors, time, date etc. are entered as numbers with or without decimal digits.

If the display shows the decimal point in a number to be entered, input of a floating-point number is requested. However, the number of digits after the decimal point is limited to the number of displayed decimal digits; i.e. the decimal point cannot be moved during input.

The digit to be changed is indicated by a bar under the digit.

The following example indicates the input of numerical values. We will change the value of shear rate (Val.[1/s]) from 0100.00 to 290.00.



In the following example, the cursor bar is located under the “1” in the entered shear rate (currently 100.00 s⁻¹).

```
Input of Values:
Val.[1/s]: 0100.00
Nr. of MP: 010
Time[s]: 0100
```

The “1” can be changed (incremented or decremented) by using the  and  keys.

Press the  key once to get:



```
Input of Values:
Val.[1/s]: 0200.00
Nr. of MP: 010
Time[s]: 0100
```

The cursor can be moved right or left by using the  and  keys. To change the next digit, press the  key:

```
Input of Values:
Val.[1/s]: 0200.00
Nr. of MP: 010
Time[s]: 0100
```

The next digit can now be changed. In order to insert “9” in place of “0”, press the  key once:



```
Input of Values:
Val.[1/s]: 0290.00
Nr. of MP: 010
Time[s]: 0100
```

Note: If you press and hold one of the keys  or  while entering numbers, the digit will first increment or decrement by +/- 1. However, after a short period of time, the process will continue automatically. This corresponds to the **Repeat Function** of computer keyboards.

In this example,  could be pressed and held until the “9” is displayed. **The repeat function is only active during numerical and alphanumeric input.**

When the desired number is displayed, accept it by pressing the  key: the cursor now moves to the first digit of the next field to be entered.

Alphanumeric inputs



Some fields allow for both numbers and letters. These are entered the same way as previously discussed for numeric fields. The available entries are: 0 through 9, A through Z, and the blank symbol “ ”. If you wish to change the letter “B” to the number “7”, press and hold the  or  keys until the “7” appears at the display.

Alphanumeric input is available when assigning a name to a user defined program, or an ID to a user defined test measurement.

VI.5 Menu Entries (MAIN menu)

Menu entries (see *Section VI.2*) either lead to submenus (e.g. “Utilities” or “Configuration”), or they start one of the Rheometer’s functions directly.

All gray fields in the tree chart in *Section VI.2* that have no further right branches start functions. Those with right branches are submenus.

Recall the keyboard layout from *Section VI.2*. By pressing  and  the cursor (black rectangle) moves up and down. The  starts a function. If a submenu is assigned to the entry it will open, otherwise the function of the Rheometer is started. The functions of the R/S+ Rheometer are described in detail in this section.

VI.5.1 MAIN menu → Run Single

This function carries out a measurement of shear stress or shear rate at a constant preset values. The physical units of preset values may be selected from:

- Shear Rate D[s⁻¹]
- Speed n[rpm]

Before you start the measurement itself, you have to input the following values:

- Selection of the measuring system used (selection from the list, operation, see *Section VI.3*)
- Selection of physical units of preset value (see above, selection from the list, operation, see *Section VI.3*). This is where you decide if you want to carry out a shear rate measurement (shear rate, speed) or a shear stress measurement (shear stress, torque).
- Input of preset values (input of numbers, operation, see *Section VI.4*).
 - $D[s^{-1}]$ The range of value depends on the measuring system
 - $n[rpm]$ 0.1 to 1,000 rpm (U/min)
 - $\tau [Pa]$ The range of the value depends on the measuring system
 - $M [\%]$ 0 to 999 %
- Input of desired number of measured points (input of numbers, operation, see *Section 6.4*). Input of the measurement duration in seconds. the minimum time interval depends on kind of the measurement and on number of measurement points. The minimum time between 2 measurement points are:
 - shear rate measurement $t_{MP} \geq 4$ s
 - shear stress measurement $t_{MP} \geq 1$ s

Note: The longer the time between two measured values, the higher the accuracy of the physical values determined!

- Input of ID (15 character maximum) for the Test Measurement (alphanumeric input, operation - see *Section VI.4*)

If you have passed these points before starting a measurement, the Rheometer will indicate where the measure points will be written to:

```
Output of MPs to:
- no output-device
- memory
<▲>menu    <ST>START_
```

Start a measurement by pressing the **[ST]** key or return to the main menu with the **[▲]** key.

This example shows that the measurement data will be written into the instrument memory. Output devices are either a printer or the RS232 serial interface of the Rheometer. Pre-selection of these devices is described in the Section “Configuration → Output mode”.

If the memory is full and you want to keep the data, you should Break the “Single Measurement” function, print out the data from the memory or send the data to a PC (see “Utilities → Print Memory”). Then you may clear the data from the memory (see chapter “Utilities → Clear Memory”) and run your test.

Tests may run with full memory but the results will not be saved. They will be shown on the LCD as they come from the instrument.

to “Run Single”, here you can also set values as a linear function of time, for example $D[s-1] = f(t)$. It is advisable to use function Run Program always when you want to carry out repeating measurement series with the same preset values and with the same measuring system. The second option is used when a user can carry out measurement without large previous information of rheology. Actually, not every person, starting a measurement, has unlimited possibilities to determine correct preset values and measurement system for a medium under study (optimal use of measurement range, irreversible rheological changes of the substance studied, etc.). 4 standard programs can be defined. How to define or to edit program is described in Section “Utilities → Edit Program”.

Function Run Program starts one of the programs defined in memory. If there is no program available, the following error message is displayed:

```
No valid program
Enter program first!
```

In such a case you have to define a program first (“Utilities → Edit Program”). Use **OK** to return to the main menu.

If programs are available, a list appears to select from. Select the program to be started (selection from the list, operation, see *Section VI.3*).

```
Select PROG to run
1) Prog xyz
2) Test
3) Prog oil 2000
```

If the **OK** key is used to select the program (in this example, the program named “Test”), this operation is followed by the option to enter an ID (identification text of the measurement). A name for the measurement may be entered here (maximum 15 characters - for alphanumeric input, see *Section VI.4*).

```
Input measuring id
ID-number: 125
ID: OIL2000 040596
```

Meas. series identification | Automatic increment at every measurement

If you have passed these points before starting a measurement, the rheometer will indicate where the measure points will be written to.

```

Output of MPs to:
- Printer
- memory
<▲>menu  <ST>START_

```

Start a measurement by pressing **[ST]** or return back to the main menu with **[▲]**.

In the above example, the measurement points will be saved to memory and printed to the printer connected to the Rheometer. Options for output devices include a printer, the RS232 serial interface or no output device. The section, “Configuration → Output mode”, describes this in detail.

If the memory is full, you should consider cancelling the “Program measurement” function, printing the data from the memory or sending it to a PC (see chapter “Utilities → Print memory”) and then clearing the data from the memory (see “Utilities → Clear memory”).

Measurements can be taken with the memory full but the results will only be shown at the LCD and will be lost after completion of the measurement. If you try to send results to a printer and it is not connected or has no paper in it, an error message will be displayed until the printer is connected and operational or until you break the activity.

When you start the measurement the instrument shows:

```

Program running...
Wait for 1.MP
#01

```

This message will be displayed until the first measuring point is displayed.

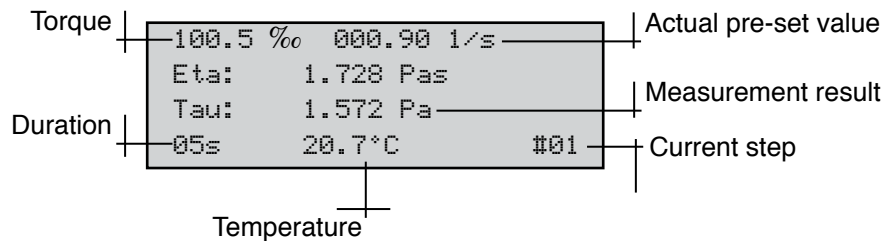

If the torque is less than 30 %o, the results may be out of instrument range. The user should consider changing the user defined values to get a torque higher than 10 %o.

If the display field for the torque indicates: “M low!”, these values are below the range of resolution of the Rheometer.

If the temperature is not to displayed, the measuring sensor is not connected and the printout of the temperature will be printed as **1000.0 °C!**

The display is updated at every new measuring point. The current measurement can be cancelled at any time with the **[ST]** key.

After measurement, or after a break, the display field for step indicates “END” or “BREAK”. The LCD alternates at intervals of about four seconds between the last displayed measuring point and information on the measurement:

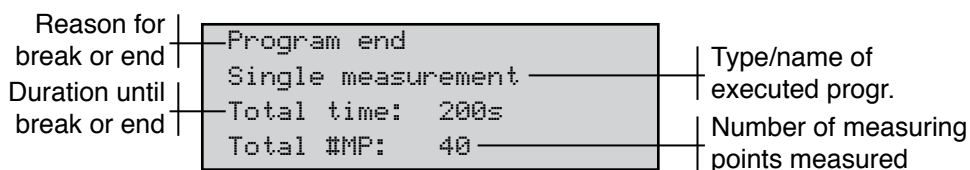

Pressing **[OK]** ends the alternating display and returns to the main menu.

VI.5.4 MAIN menu → Remote

The “Remote” function initiates measurements to be made under PC control. In this mode, all functions of the R/S+ Rheometer are controlled by a PC. For PC-controlled measurements, you need the software package RHEO3000. This software operates under Microsoft Windows 2000™, Windows XP™, and Vista™. More detailed information on RHEO3000 software can be obtained from your Brookfield or an authorized dealer.

After selecting the Remote option, the Rheometer displays the following:

```
Remote
Wait for RS232...

<ST>=stop
```

The Rheometer waits for communication with a PC. Data transfer between the PC and the Rheometer is performed through the RS232 serial interface of the R/S+ Rheometer.

If RHEO3000 is installed on the PC, the REMOTE (MEASURE) program can be run and this operation can be ended at any time by the **[ST]** key. The current measurement is also cancelled by pressing the **[ST]** key in REMOTE operation.

On completion of the communication with the PC, the LCD shows: “Remote done ...”

Pressing the key **[ST]** will return the display to the Main Menu.

During measurement in REMOTE operation, the LCD will display various information which to provide troubleshooting information in case errors occur; this information should be disregarded.

VI.5.5 MAIN Menu → Utilities

Entry to open the “Utilities” submenu - see *Section VI.6*.

VI.5.6 MAIN Menu → Configuration

Entry to open the “Configuration” submenu - see *Section VI.6*.

VI.6 Menu Entries in the Utilities Menu

The Utilities menu contains several useful functions:

Zero Calibration	Initiates the zero calibration procedure of the rheometer
Edit Programs	Input or modification of programs which are started with Run Program
Print Programs	Prints all parameters of all the programs in memory to the printer
Measuring Systems	Input of measuring system parameters or generation of new measuring systems
Print Memory	Output of data in memory to the printer or to the serial interface
Delete Memory	Clears all data from memory
Meas. Temperature	Measures temperature without running a measurement

The following sections explain these options in more detail.

VI.6.1 Utilities → Zero calibration

The function “Zero calibration” serves to calibrate the Rheometer zero point. This function continues for approximately 10 minutes and should be done once a week.



Before starting this function, be sure the R/S+ Rheometer has warmed up for at least 10 minutes, and that NO measuring element is in the measuring element coupling.

Confirm the command that the measuring system is removed by pressing the **OK** key (start of zero point calibration), or press the **ST** key to return to the Utilities menu.

Zero point calibration will proceed automatically and comprises several measuring series at different speeds. The progress of calibration is shown by the number of executed steps of the total steps. If an error message appears during zero calibration, repeat the zero calibration. If the error message is displayed again there may be a technical fault (→ Repairs).

After successful calibration, the values of the zero point are stored internally. These values are preserved until the next calibration.

Press the **OK** key to save values. Press any other key to return to the Utilities menu without saving.

Note: You can cancel zero point calibration at any time with the **ST** key. The zero point values determined up to that point will be ignored.

VI.6.2 Utilities → Edit Program

This function allows the input of new, and the modification of existing programs. The programs may be run after successful creation via the menu level “Program Measurement” in the main menu.

The following values are user-definable in a program:

- measuring system to be used
- number of steps
- start and end value of each step
- number of measurement points for each step
- duration of each step

Preset value as a function of time:

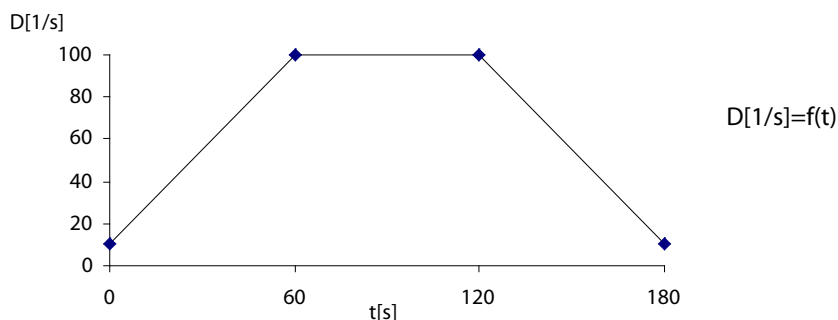

A standard measurement is shown in the following example:

1st step: shear rate increases within 60 sec from 10.00 to 100.00 s⁻¹.

2nd step: shear rate remains at 100.00 s⁻¹ for 60 seconds

3rd step: shear rate decreases from 100.00 back to 10.00 s⁻¹ within 60 seconds

This measurement consists of three steps, each lasting 60 seconds and containing a number of measuring points.

The following is an example to explain the input of a program:

Apart from the shear rate $D [s^{-1}] = f(t)$, the preset value can also be defined as:

speed $n [rpm] = f(t)$

torque M [%o] = f(t) and
shear stress τ [Pa] = f(t)

Steps are always linear, measurement points are also defined as linear; i.e. logarithmic steps are not possible. For logarithmic measurements, you need RHEO3000 software.

Preset value substeps in a defined step according to the following equation:

$$\text{Preset Value} = \text{End Value} - \text{Start Value} / (\text{Number of Measuring points} - 1)$$

The first user defined value (=the first measuring point) is always the start value of the ramp. The last measuring point is determined as the end value of the user defined value range. As in our example, to reach the values $D = 10, 20, 30, \dots, 100$ [s^{-1}] a starting value of 10 [s^{-1}] is used with increments of 10, therefore, 10 measuring points is required. To check: $100 - 10 / (10 - 1) = 10$.

$$\text{Number of Measurement Points} = ((\text{End Value} - \text{Start Value}) / \text{Preset Value}) + 1$$

Back to the example.

After selection of the menu level “Edit Program”, the user will be prompted to select the program.

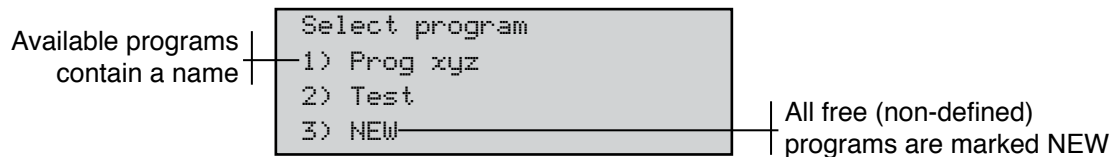

All free programs are initially marked as NEW. To avoid overwriting existing programs, select NEW as a program to be edited and select a measuring system. After selection of the program with the **OK** key, you will be requested to select a measuring system.

Attention: Any defined program **MUST ALWAYS** be executed with the same measuring system, otherwise improper results will be calculated.

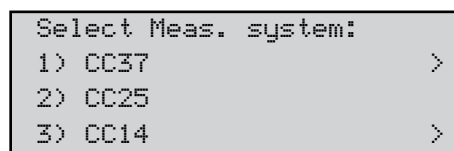

After selecting the measurement system, enter the number of steps (number of ramp and straight line functions). The number of steps can range from **1 to a maximum of 10 steps**. In this example, we need three steps, so the number “01” is changed to “03” - (see input of numbers - *Section VI.4*). The message “Range error” will appear if <1 or >10 is entered.

```
Nr of steps: 03
```

Input number of steps 1 - 10. This example is 03.

After entering the number of steps, the type of measurement needs to be entered.

```
Select Input:
-D[1/s]
-n[rpm]
-Tau[Pa] >
```

Available Measurement Types	User Defined Range
Shear Rate D[s ⁻¹]	Depends on the measuring system
Speed n[rpm]	0.1 - 1,000 rpm
Shear Stress Tau [Pa]	Depends on the measuring system
Torque M[‰]	0 - 999 promille (= 0 to 50 mNm)

Select the type of measurement and press the **OK** key (in our example “D[1/s]”). Now enter the user defined values for each step one after the other.

The following inputs have to be made for each step:

```
Input Step Nr1
Start[1/s]:0010.00
End[1/s]: 0100.00
Nr of MP: 010
```

Start Value
End Value
Number of Measuring Points (data points)

(Input of numbers: see *Section VI.4*)

Minimum and maximum start and end values depend on the selected measuring system for shear rate (D[s⁻¹]) and shear stress (Tau [Pa]). At input, the Rheometer checks the start and end values and indicates the message “Range error” if out of range:

```
Range error
Start value:
Min: 0.90
Max: 1032.80
```

Allowed minimum value
Name of value out of range
Allowed maximum value

For example, this a range error message would be displayed if a start value for D[s⁻¹] is not within the range of 0.0 - 1032.8 s⁻¹ when using measuring system CC25.

If the start value, end value and number of measuring points are acceptable, the user will be prompted for Step Duration:

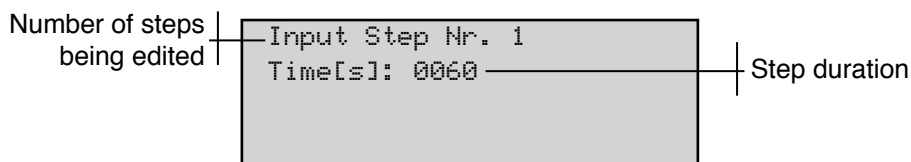

Minimum step duration:

Available Measurement Types	User Defined Range
Shear Rate $D[s^{-1}]$	$t_{min} = \text{number of measuring points} * 4 \text{ s}$
Speed $n[rpm]$	$t_{min} = \text{number of measuring points} * 4 \text{ s}$
Shear Stress $\tau [Pa]$	$t_{min} = \text{number of measuring points} * 1 \text{ s}$
Torque $M[\%o]$	$t_{min} = \text{number of measuring points} * 1 \text{ s}$

Maximum step duration: **3600 s**

The instrument will automatically check the input. If there is a range error, “Range error” will be displayed together with the allowable range.



The more time between two measuring points, the higher the accuracy of the determined physical parameters!

The input procedure for start and end value, number of measurement points and step duration is repeated for the next step. The procedure is repeated until all steps have been entered.

The program will then prompt the user for a program name.

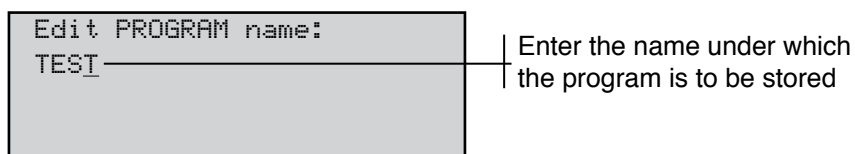

For this example, we will use “TEST”. (For the input of alphanumeric texts see *Section VI.4*)

The instrument will prompt the user to store the Program with the Name:

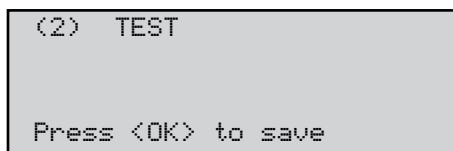

Press OK to store the program.



If any other key besides **OK** is pressed, the entries are abandoned and those parameters of the program position existed before editing will be preserved.

VI.6.3 Utilities → Print Programs

This function will print the parameters of the defined programs in memory.

If the printer is not ready for operation when the “Print Programs” function is initiated, the following error message will be displayed:

```
ERROR #1
Printer not ready!

<OK>cont.  <ST>stop
```

If this error message appears, ensure the printer is ready and contains paper.

Press **OK** to try printing again or press **ST** to return to the menu.

VI.6.4 Utilities → Measuring Systems

This function provides a method to create new measuring systems or change existing measuring systems.

The following values can be edited:

- name of measuring system
- shear rate factor K [min/s] (k_gamma)
- shear stress factor %o [Pa] (tau_prom)



Only authorized personnel are permitted to change constants of the measuring system!

After starting the function, you will be prompted to select the measuring system you want to edit. Select the list item “NEW” to generate a new measuring system.

```
Select Meas. system:
1) CC37
2) CC25
3) CC14
```

After selection of the measuring system entry, the user is prompted to enter a name,

tau_prom and k_gamma.

```
Enter Meas. syst. #4
Name: CC25
tau_prom: 01.1418
k_gamma: 01.2910
```

The measuring system name is entered in alphanumeric form; the factors tau_prom and k_gamma are entered as numerical entries (see *Section VI.4*).

After entry, the system will prompt the user to store the new parameters.

```
Press <OK> to save
Name: CC25
tau_prom: 01.1418
k_gamma: 01.2910
```

Use **OK** to store the new information, otherwise press the **ST** to return to the menu without storing.

VI.6.5 Utilities → Print Memory

This function allows the output of the data stored in the instrument memory to either a printer or to the RS232 serial interface of the Rheometer.

The instrument will prompt you to select the output device, as follows:

```
Sel. output-device:
-Printer
-RS232
```

a) Output to printer:

The printer must be connected to the Rheometer and ready for operation.

b) Output to the RS232 serial interface:

The data receiving side (typically a PC) must be set to the data transfer parameters and receptive as data transfer from the Rheometer to the receiving device is carried out without handshake. If the receiving side is not set up properly, the data will either not be transmitted or transmitted to Null. (see *Section VI.8 “Serial Data Transfer”*).

After choosing the output device you are prompted to select the program to be printed or transferred.

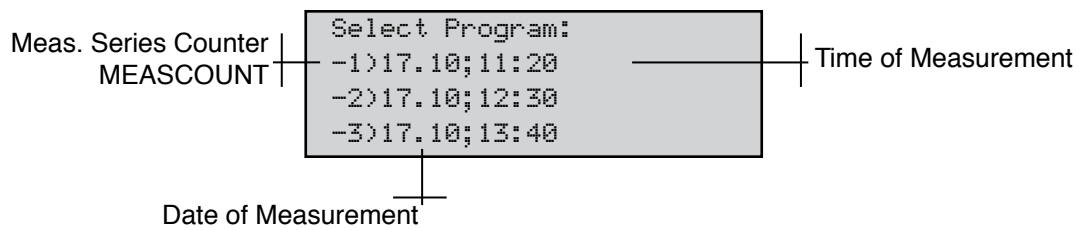

The data of the program will print as a table to a printer or will be transferred via the serial interface. After completion of data transfer, the Rheometer returns to the Utilities Menu.

VI.6.6 Utilities → Clear Memory

This function deletes all measured data stored in the memory of the R/S+ Rheometer.

Before deleting, ensure that the data has been archived to a printer or PC. Before the memory is cleared, the following prompt is displayed:

```

Delete Memory?
-NO
-YES
  
```

If “YES” is selected, the results will be cleared from the memory; if “NO” is selected, no deletions are made and the user is returned to the menu.

VI.6.7 Utilities → Measure Temperature

This function displays the temperature with the temperature sensor connected to the Rheometer.

After initiating this function, the temperature is measured permanently:

```

Temperature:
20.5°C

<OK>=return

```

Push the **OK** key to return to the Utilities menu.

VI.7 Menu Entries of the Configuration Menu

The Configuration menu allows the user to set parameters on the Rheometer. The entries:

- **Set output-mode:** Defines if data is output to a printer or to the serial interface during measurement.
- **Set meascount mode:** Defines whether the measurement counter MEASCOUNT is reset daily or not.
- **Set meascount=0:** Resets the MEASCOUNT counter to 0.
- **Set time/date:** Inputs date and time.
- **RS232 parameters:** Sets data transfer parameters of the serial interface RS232.
- **Language:** Selects language for user prompts.
- **Service:** For service personnel only
- **Service2:** For service personnel only

These functions are explained in more detail in the following sections.

VI.7.1 Configuration → Set Output Mode

This function defines the output device (printer, serial interface) which will receive the results. This setting is independent of the internal storing of results in memory. When tests are run, the data is automatically stored in memory in addition to the configured output device.

After selecting this function you are prompted for possible output devices:

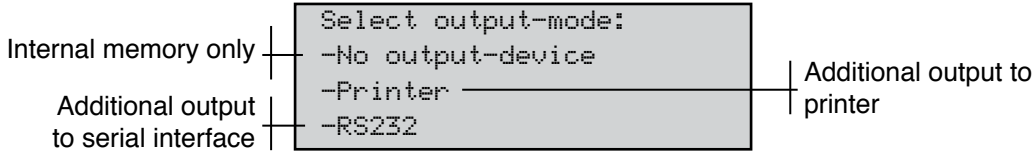

Choice of an output device is stored in the instrument by pressing the **OK** key. **This selection remains stored even after switching off the instrument!**

The set output device is prompted before the start of every measurement (see also “Main menu-> Run Single” and “Main menu-> Run Program”).

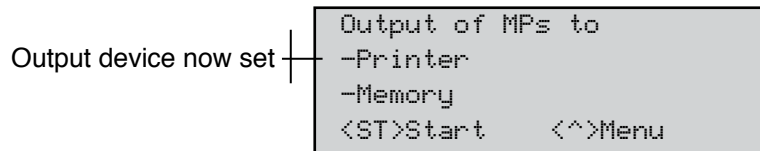

After selecting an output device, be sure that before the start of every measurement:

- a) the printer is connected to the Rheometer and is ready for operation. If the printer is not ready, you cannot start the measurement.
- b) SERIAL INTERFACE (RS232): the receiving device (normally a PC) is set to the data transfer parameters of the Rheometer (see *Section VI.7.5 "RS232 Parameters"*) and ready to receive data. If the receiving side is not ready, the data will not be transmitted or will be transmitted to Null (see *Section VI.8 "Serial data transfer"*).

VI.7.2 Configuration → Set MeasCount Mode

The measurement series counter MEASCOUNT increases by 1 before each measurement is started. The measurement series counter serves to identify a measurement series. The counter increments until it is reset manually ("MeasCount=0") or automatically. The user defines whether the measuring counter is reset daily or not.

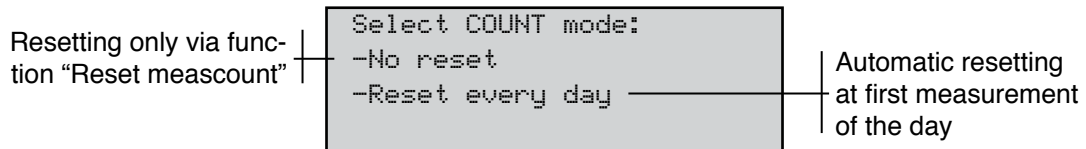

After choosing one of two reset modes the user will be returned to the Configuration Menu.

VI.7.3 Configuration → Reset MeasCount

This function resets the measurement series counter (regardless a MEASCOUNT mode set) = manual reset of the measurement series counter.

No further selections or settings are required.

VI.7.4 Configuration → Set Time/Date

This function allows the user to set the internal clock and internal calendar.

The time is set in 24 hour format.

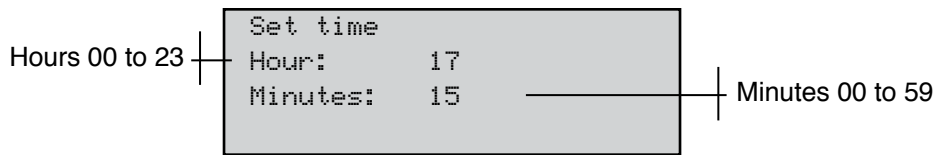

The date is set as dd.mm.yy format:

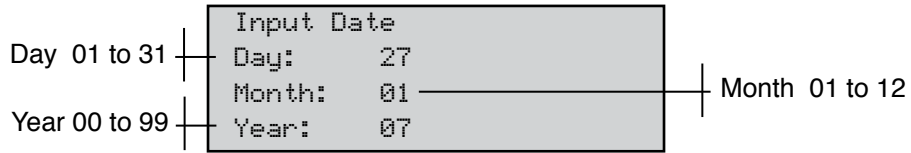

After setting time and date you will be prompted to store the clock to the new time.

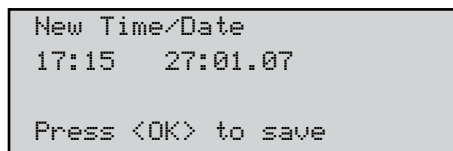

Set the time using the **[OK]** key, or return to the menu without storing by pressing **[ST]**.

Note: The new time is entered into the clock only after the **[OK]** key is pressed. Note that storing of the time sets the seconds to 00.

VI.7.5 Configuration → Set RS232 Parameters

This function allows the preselection of interface parameters.

The serial interface operates **without handshake**.

Data is transferred as **ASCII text**.

Parameters to Set	
Baud rate [Baud]	110, 150, 300, 600, 1200, 2400, 4800, 9600, 19200
Parity	n(= no parity) e(= even) o(= odd)
Stopbits [Bit]	1 or 2
Databits [Bit]	7 or 8

The standard setting is:

Baud rate = 4800

Parity = n

Stopbit = 1

Databits = 8



If you change these settings, you also have to set new transfer parameters of the receiving device!

After starting the function “RS232 Parameters”, you will be prompted to enter the baud rate:

```
RS232: 4800,8,n,1
Change RS232-Par.?
<OK>YES    <ST>NO
```

Press the to initiate the input of parameters.

You may enter the following parameters in succession:

- Baud rate [Baud]: 110, 150, 300, 600, 1200, 2400, 4800, 9600, 19200
- Databits [Bit]: 7 or 8
- Parity: n (=none) e(=even) o(=odd)
- Stopbits [Bit]: 1 or 2

Select the required parameter from the list of available parameters and accept by pressing .

Example: Baud rate

```
Baud rate:
-4800
-9600
-19200
```

When all parameters have been selected the new parameters are displayed:

```
RS232: 19200,8,n,1
<OK>=storing
```

Accept the set parameters by pressing .

The new settings are now stored and will remain in the memory even after switching off the instrument.

VI.7.6 Configuration →Language

This function selects the user language of the R/S+ Rheometer. Available languages are:

- German
- English

Select desired language and press . The selected language will be preserved in the instrument even after it is switched off.

VI.7.7 Configuration →Service

These functions are for service personnel only. Password-protected!

VI.8 Serial Data Transfer via the RS232 Interface

Serial data transfer should only be done when the user of the Rheometer has basic knowledge of data processing and is capable of changing data transfer parameters on the sending and receiving sides.

Data can only be transferred successfully when transmitter (R/S+ Rheometer) and receiver (e.g. a PC) fulfill the following requirements:

1. The instruments are properly connected by the interface cable which is delivered with the instrument. **Caution: Both instruments must be switched off while the connection is made!** (Pin assignment: see Appendix to this documentation).
2. The transmitter (R/S+ Rheometer) and the receiver are set to identical data transfer parameters (for R/S+ Rheometer, see Section VI.7.5. “RS232 Parameters”).
3. **The receiver** has enough computing and memory capacity to receive or store the data.

The following example demonstrates reception by means of the terminal program under Microsoft™ Windows.

1. Switch the Rheometer and the PC off.
2. Connect the Rheometer (connector RS232 at the back side of the instrument) with a free serial interface (e.g. COM2) of the PC. Use the cable supplied by Brookfield.
3. Switch the PC and the Rheometer on.
4. Set the data transfer parameters at the Rheometer (see *Section VI.7.5*). Here: Standard setting 4800 Baud, Parity n, Stopbit 1, Databit 8.
5. Select the RS232 interface as the output device at the Rheometer (see *Section VI.7.1*).
6. Open the “Windows Accessories” program group on the PC.

7. Start the “Terminal” program.
8. Select the menu level “Settings” → “Data transfer.”
9. First, a window will appear where you can set the data transfer parameters:
 - Select from “Connection” the COM-port to which the Rheometer is connected.
 - Set “Baud rate” to “4800”.
 - Set “Databits” to “8”.
 - Set “Stopbits” to “1”.
 - Set “Parity” to “No parity”.
 - Set “Protocol” to “No protocol”.
 - Deactivate “Parity check” checkbox (if crossed).
 - Deactivate “Carrier signal detection” checkbox (if crossed).
 - Finish input by pressing .
10. Select the menu option “Settings” → “Terminal Settings”
A window will appear where the user can set the terminal functions:
 - Select “English” option.
 - Activate “IBM in ANSI” (if not crossed yet).
11. Parameters of the terminal program that have been changed up to this time can be stored under the menu option “File” → “Save” by entering the file name, e.g. “R/S+.TRM”.

(When the terminal program is started again, this file with can be opened by: “File” → “Open” and load the parameters for data transfer with the R/S+ Rheometer.
12. Now select the menu level “Transfer” → “Text file reception”.
 - Enter the file name under of the stored data sent from the Rheometer (e.g. “TEST.TXT”).
 - The message “Receiving: TEST.TXT” will then appear in the status line of the terminal program.
13. The terminal program is now ready to receive data (for more detailed instructions or troubleshooting on the terminal program, please read your documentation).
14. Start measurement with the Rheometer. Measuring points should appear as text on the PC display after a short period of time.
15. When the data of one or several measurements have been transferred into the selected text file, terminate the data transfer and end the terminal program.

Should a receiver other than a PC be used for serial data transfer, the pin assignment of this receiver must be checked before the connection is made. You can find the pin assignment of the serial interface plug as well as of the data link cable in the Appendix to this documentation.

VII. Measurements

VII.1 Measuring in Manual Mode

You can measure in manual mode by following these brief instructions:

- Install the R/S+ Rheometer on the stand (see *Section III*).
- Connect the AC adapter (see *Section III*).
- Connect the printer, which is optional (see *Section III*).
- Attach the Measuring System, load the sample (see *Section V*).
Make sure no substance or solvent enters the measuring element coupling, the measuring drive or the electronic unit.
- Wait until the sample reaches the desired temperature.
- Start a Single Point Test or a Program Measurement (see *Section VI*).
- After running the test, switch off of the temperature control, wait until the cooling/warming of the returns to room temperature.
- Clean the sample area and Measuring System.

VII.2 Measuring with Water Jacket

- Install the R/S+ Rheometer (see *Section III*).
- Connect the AC adapter (see *Section III*).
- Connect the printer if necessary (see *Section III*).
- Mount the temperature control device water jacket and connect, if desired, the built-in Pt100 (see *Section III*).
- Fill and mount the standard measuring system (see *Section V*).
- Check the presence of temperature control medicum and cooling liquid (if cooling device is used)
- Wait for temperature control until the attainment of the desired temperature in the measuring substance.
- Start a program or a single measurement (see *Section VI*).
- After ending of the measurement and switching off of the temperature control wait until the cooling/warming of the medium to room temperature.
- Remove and clean the measuring system.

VII.3 Measurement with Cone/Plate Attachment

- Mount the R/S+ Rheometer on the stand (see *Section III*).
- Connect the AC Adapter (see *Section III*).
- Connect, if necessary, the printer (see *Section III*).
- Mount the cone/plate measuring device “Cone/Plate Attachment” and connect the built-in PT100 (see *Section III*).
- Mount, adjust and fill the standard measuring system (see *Section V*).
- Check the presence of the temperature control liquid.
- Wait for temperature control until the attainment of the desired temperature in the measuring substance.

- Start a program or a single measurement (see *Section VI*).
- After ending of the measurement and switching off of the temperature control, wait until the cooling/warming of the medium to room temperature.
- Remove and clean the measuring system.

VII.4 Measurement in Remote Mode

- Mount the R/S+ Rheometer on the stand (see *Section III*).
- Connect the AC Adapter (see *Section III*).
- Connect the RS232 cable between the rheometer and the PC.
- Switch on the R/S+ Rheometer and select the menu point “Remote”
- Switch on the computer and all peripheral devices.
- Start the RHEO3000 Software.
- Load a program in the RHEO3000 Software.
- Fill and mount your measuring system (see *Section V*).
- Check the presence of temperature control medium and cooling liquid if cooling device is used
- Wait for temperature control until the attainment of the desired temperature in the measuring substance
- Start the program
- After ending of the measurement and switching off of the temperature control, wait until the cooling/warming of the medium to room temperature.
- Remove and clean the measuring system.

VIII. Technical Data

R/S+ Rheometer	
Dimensions	480 mm x 300 mm x 290 mm
Weight	8 kg
Nominal operating voltage	± 15V, 5V
Power consumption (average)	12W
Power consumption (maximum)	22W
Environmental Conditions	
<u>Temperature</u>	
in operation	10° to 40°C
out of operation	10° to 45°C
<u>Relative humidity (not condensable)</u>	
in operation	20% to 80%
out of operation	10% to 90%
Accuracy	± 3-5% of measured value where $M > 30$ ± 1 digit
Torque range	1.5 to 50 mNm
Torque resolution	0.01 mNm
Speed range	0.1 to 1,000 rpm
Angle resolution	15.7 μ rad
Temperature range	-20° to +180°C depending on the geometry used
Range of shear rate	0.9 to $4 \times 10^3 \text{ s}^{-1}$ depending on the geometry used
Range of shear stress	0.7 to $3.4 \times 10^4 \text{ Pa}$ depending on the geometry used
Viscosity range	1×10^{-3} to $3 \times 10^{-3} \text{ Pa}\cdot\text{s}$ depending on the geometry used. Practical low limit is .050 Pa·s for cone/plate measurement.
The given range is a standard value (not maximum value)	

AC Adapter	
Dimensions	160 mm x 85 mm x 35 mm
Weight	0.5 kg
Power supply	
Operating voltage	100 to 240 VAC
Output voltage	5V, ± 15V DC
Output current	2A, 0.9 / -0.2A
Output power	20W
Frequency	50 to 60 Hz
Environmental Conditions	
<u>Temperature</u>	
in operation	+10° to +40°C
out of operation	+10° to +45°C
<u>Relative humidity (not condensable)</u>	
in operation	20% to 80%
out of operation	10% to 90%

Water Jacket Assembly	
Dimensions (width x height x depth)	94 mm x 55 mm x 170 mm
Weight	600 g
Temperature Range Standard range with cooling device	-10° to +90°C -20° to +180°C

Preset, Measured and Evaluated Values

Value	Symbol	Physical Unit
Speed	n	[min ⁻¹]
Torque (relative) (1000 % _{cc} = 50 mNm)	M	[1}
Temperature	T	[°C]
Time	t	[s]
Shear rate	$\dot{\gamma}$	[s ⁻¹]
Shear stress	τ	[Pa]
Dynamic viscosity	η	[Pas]

IX. Guarantee

Brookfield Engineering Laboratories guarantees the faultless functioning of this instrument insofar as it is used and maintained appropriately and connected and handled in accordance with this Operating Manual.

The guarantee period shall be 1 year from the date of delivery.

The place of guarantee fulfillment is Brookfield Engineering in Middleboro, MA (USA).

All claims of the customer concerning guarantee and damages shall be forfeited if he has handled the supplied goods improperly, worked on them, or given them to a third party for reworking without our prior approval.

The total liability of Brookfield Engineering Laboratories and your exclusive claim shall be limited, at Brookfield's choice, to either

(a) the refund of the price paid

or

(b) the repair or replacement of the instrument which does not meet the requirements of the limited guarantee of Brookfield Engineering Laboratories and has been returned with a copy of your receipt to Brookfield Engineering Laboratories. This limited guarantee shall not apply if the instrument's failure is a result of accident, misuse or incorrect application. For a replacement delivery Brookfield Engineering Laboratories guarantees only for the rest of the original guarantee period or for 30 days, whichever is longer.

Brookfield Engineering Laboratories precludes any further guarantee for the instrument and related manuals and written materials.

Neither Brookfield nor the suppliers of Brookfield shall be liable for any damages (lost profit, business interruption, loss of business information or of data or any other financial losses included) that arise due to usage of this Brookfield product or due to the inability to use this Brookfield product, even if Brookfield was informed of the possibility of such damage occurring.

In any case, the liability of Brookfield Engineering Laboratories shall be limited to the amount paid for this product. This exception shall not apply to damages which were caused by intention or gross negligence on the side of Brookfield. Nor shall claims be affected that are based on mandatory laws concerning product liability.

Furthermore the guarantee conditions of "General Delivery Conditions for Products and Services of the Electric Industry" are valid.

Appendix A

A.1 Data Sheets of Standard Measuring Systems

Table A-1: Coaxial Cylinder Measuring Systems according to DIN 53019/ISO3219 (consisting of measuring cone and the bottom measuring plate of the instrument)

Measuring System	CC40	CC25	CC14	CC8
Shear rate range [s ⁻¹]	0.215-2,150	0.13-1,290	0.13-1,290	0.13-1,290
Shear stress range [Pa]	2.87-287	11.4-1,140	65-6,500	350-35,000
Viscosity range [Pa·s]	0.0013-1,340	0.009-8,800	0.05-50,350	0.27-270,000
Filling volume [ml]	60	17	3	0.5
Shear rate factor $K\dot{\gamma}$ [min/s]	2.148	1.291	1.291	1.291
Shear stress factor τ_{∞} [Pa]	0.2874	1.1418	6.501	34.844
Radius of measuring bob R_1 [mm]	20.0	12.5	7.0	4.0
Radius of measuring cup R_2 [mm]	21.0	13.56	7.59	4.34
Radius of shaft R_s [mm]	3.5	3.5	2.1	1.2
Angle of measuring bob cone α [°]	120	120	120	120
Distance between lower edge of meas. bob and meas. cup bottom L' [mm]	20.5	15.5	13	12
Immersion of measuring shaft L'' [mm]	22	12.5	7.0	4.0
Length of meas. bob L [mm]	60.0	37.5	21	12
Ratio of Radii $\delta = R_2/R_1$	1.050	1.0847	1.0847	1.0847
Resistance coefficient c_1	1.1	1.1	1.1	1.1

The given ranges are standard values (not maximum values)

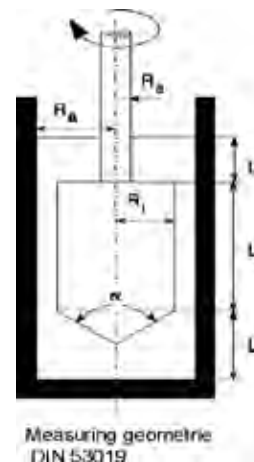
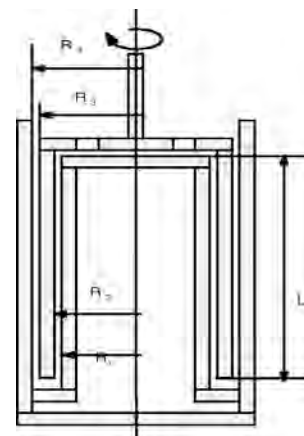

Table A-2: Double Gap Cylinder Measuring System According to DIN 54453
(consisting of measuring bob and measuring cup)

Measuring System	DG DIN
Shear rate range [s ⁻¹]	0.43-4,340
Shear stress range [Pa]	0.83-83
Viscosity range [Pa·s]	0.00019-190
Filling volume [ml]	16
Shear rate factor $K\dot{\gamma}$ [min/s]	4.3465
Shear stress factor $\tau_{\%}$ [Pa]	0.0833
Inner radius of measuring bob R_2 [mm]	19.72
Outer radius of measuring bob R_3 [mm]	20.5
Inner radius of measuring cup R_1 [mm]	19.25
Outer radius of measuring cup R_4 [mm]	21.0
Length of measuring bob L [mm]	111
Ratio of radii $\delta = R_2/R_1 = R_4/R_3$	1.0244
Resistance coefficient c_L	1



The given ranges are standard values (not maximum values)

Table A-3: Cone/Plate Measuring Systems
(consisting of measuring cone and measuring device Cone/plate)

Measuring System	C25-1/30	C25-2/30	C50-1/30	C50-2/30
Shear rate range [s ⁻¹]	0.6-6,000	0.3-3,000	0.6-6,000	0.3-3,000
Shear stress range [Pa]	122-12,220	111-12,220	15.3-1,530	15.3-1,530
Viscosity range [Pa·s]	0.02-20,300	0.04-40,700	0.003-2,500	0.005-5,000
Filling volume [ml]	0.08	0.3	0.7	1.5
Shear rate factor $K\dot{\gamma}$ [min/s]	6.00	3.00	6.00	3.00
Shear stress factor $\tau_{\%}$ [Pa]	12.223	12.223	1.5979	1.5979
Radius of measuring cone R [mm]	12.5	12.5	25	25
Angle of measuring bob cone α [°]	1	2	1	2
cone truncation	50	50	50	50

The given ranges are standard values (not maximum values)

The data in the following table is for plate/plate systems and is valid for a measuring gap of 1 mm.

For other plate distances, please calculate $K\dot{\gamma}$ with the formula:

$$K\dot{\gamma} = (2\pi/60) * (R/H)$$

R = radius, H = gap

Table A-4: Plate/Plate Measuring Systems
(consisting of measuring cone and measuring device Cone/plate)

Measuring System	P25/30	P50/30
Shear rate range [s ⁻¹]	0.13-1,310	0.26-2,600
Shear stress range [Pa]	163-16,300	20.4-2,040
Viscosity range [Pa·s]	0.125-125,000	0.008-7,500
Filling volume [ml]	0.5	2.0
Shear rate factor $K\dot{\gamma}$ [min/s]	1,309	2,6175
Shear stress factor τ_{∞} [Pa]	16,2297	2,037
Radius of measuring plate R [mm]	12.5	25.0

The given ranges are standard values (not maxim

A.2 Error Messages

The R/S+ Rheometer is user-friendly regarding errors. When errors occur, they are trapped, and the user is informed on the LCD. The most frequent error messages are explained in this chapter.

Range Error

Cause: User's error at input. The user has tried to input a value that is less than the allowed minimum value or is more than the allowed maximum value.

Example of Faulty Input of a Preset Value:

Allowed minimum value	Range error	Name of value out of range
	End value: _____	
	Min: 0.90	
	Max: 1032.80	

What to Do: Enter the value again. Be sure that the new value is within the allowed value range.

Printer Error

Cause: The printer has been selected as the output device but is not ready for printing.

- a) printer cable is not connected to the rheometer
- b) paper is out, printer is not on line, other printer errors

Example of Print Error Message



- What to Do:*
- a) make sure printer cable is connected to the rheometer
 - b) make sure paper tray has paper
 - c) check that the “ready” LED lights of the printer are on
 - d) remove the error cause at the printer and press OK at the rheometer
 - e) press ST to abort the process if you cannot find the error cause.

Zero Calibration Error

Cause: An impermissibly high value was measured during the zero point calibration of the rheometer

Example Message

```
Error #3
Zero cal. error!
Please retry cal.
<OK> cont.    <ST> stop
```

- What to Do:*
- a) press ST
 - b) ensure the measuring system has been removed from the rheometer
 - c) retry zero point calibration - if error occurs again, this is an indication of a fault in the measuring instrument

BREAK: Torque Max

- Cause:* The maximum torque has been exceeded during a measurement
- a) utilization of the measuring range is inappropriate for the measured medium
 - b) rotation element choked in the measuring cup

Example Message

```
BREAK: torque max!  
Single MODE  
total MP:      10  
total time:    60
```

- What to Do:*
- a) press OK
 - b) check whether the measuring system has been fastened properly at the rheometer
 - c) if fastened properly, select smaller shear rates or speeds for this measurement or use a measuring system with a higher shear stress factor

BREAK: Speed Max

- Cause:* The maximum speed has been exceeded during a measurement
- a) the selected shear stress or torque value for this measurement is too high
 - b) a torque or shear stress measurement has been started without substance in the measuring cup

Example Message

```
BREAK: speed max!  
Single mode  
total MP:      10  
total time:    60
```

- What to Do:*
- a) press OK
 - b) select smaller shear stress or torque for this measurement

A.3 Pin Assignment of the Serial Data Cable

The R/S+ Rheometer is equipped with a serial interface with a 25-pin sub-D-connector (male) at the back side of the instrument. The serial interface is marked as RS232.

The signal levels are in the range of +12 V and -12 V in accordance with RS232.

Pin assignment of the serial data cable for serial data transfer to a PC:
Unmarked pins must not be connected!

Rheometer side:

25-pin Sub-D-connector (female)
View on soldered connections
All other pins must not be connected!

PC side:

9 pin, sub-D-connector (female)
View on soldered connection

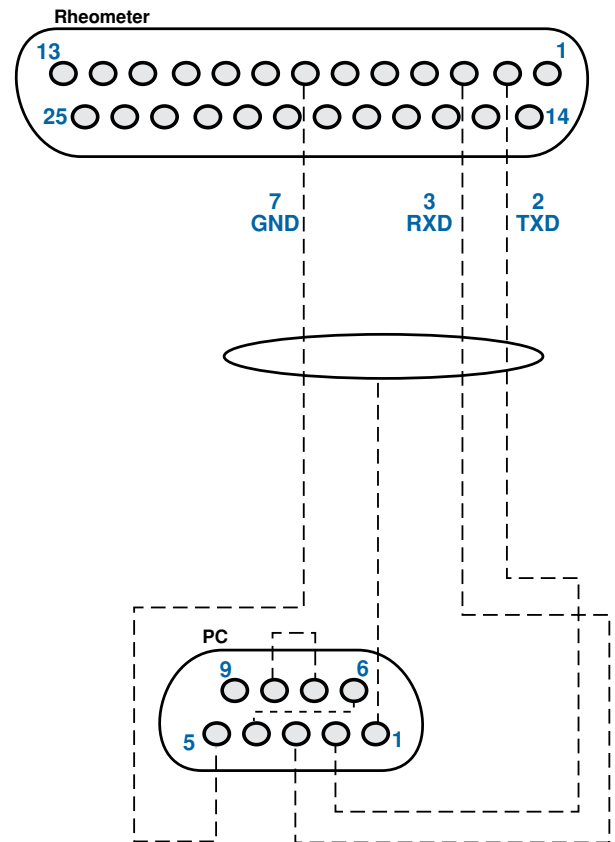

A.4 Requirements to the AC Power Connecting Cables

The AC adapter unit of the R/S+ Rheometer permits operation of the Rheometer with supply voltages ranging from 100 to 240 VAC with frequencies from 50 to 60 Hz.

The main connecting cable supplied with the R/S+ Rheometer may not, in some cases, meet the requirements of every country. It is absolutely necessary that you use a main connecting cable that meets the specific requirements and regulations of the relevant country.

The following information explains the requirements that are to be taken into account when choosing the main connecting cable.

General information

- The connecting cable must be permitted (authorized) in the country where it is used.
- The mains cable should be at least 2 m and at the most 3 m long.

USA and Canada

- UL-permission and CSA Certificate are required for the mains connecting cable.
- The following minimal requirements are valid for the cable:
 - No. 18 AWG
 - Type SV or similar
 - 3-phase
- The cable must have a nominal rating of at least 10 A.
- The main plug of type NEMA 5-15P (15A, 125V) or NEMA 6-15P (15A, 250V) must have grounding contact.

Japan

The following cable types and connection values are required in Japan:

- All parts of the cables (cable, socket and plug) must have brand name and registration number according to the Dentori law.
- The following minimal requirements apply to the cable:
 - 0.75 mm², 2-phase
 - Type VCT or VCTF
 - 3-phase
- The cable must have a minimum nominal rating of 7 A.
- The mains plug must be a 2-pin plug with grounding contact according to the Japanese Industrial Standard C8303 (15A, 125V).

Other countries

- The connectors of the mains connecting cable must be approved and certified by the responsible authorities in the respective countries. These authorities are:

Australia – EANSW	Great Britain – BSI
Austria – OVE	Italy – IMQ
Belgium – CEBEC	Netherlands – KEMA
Denmark – DEMKO	Norway – NEMKO
Finland – SETI	Sweden – SEMKO
France – UTE	Switzerland – SEV
Germany – VDE	

- The cable must be three-phase HAR-cable, type HO5VV-F3, with a minimal phase cross-section of 1.0 mm². The main connecting cable must be permitted for a rating of at least 10 A and, depending on country, a nominal voltage of 125 V or 250 VAC.

Appendix B Calibration Check Procedure

B.1 Equipment

R/S+ Cone/Plate Rheometer with appropriate cables

Temperature control apparatus¹

Flat edged non-metal spatula

Cone Spindle and Certified Mineral Oil Viscosity Standard:

One of the following²:

- RC25-1 Cone Spindle with Fluid B41000
- RC50-1 Cone Spindle with Fluid B11000
- RC50-2 Cone Spindle with Fluid B41000
- RC75-1 Cone Spindle with Fluid B4900
- RC75-2 Cone Spindle with Fluid B4900

RHEO3000 Applications Software loaded onto a PC (optional)

Reminders/Comments:

- A calibration check can be performed with or without software.
- The rheometer should always be allowed 10 minutes minimum to warm up.
- Never lift your rheometer by the head, shaft, coupling element, or measuring element coupled to the machine.
- After the spindle has been lowered on to a sample, uncouple the spindle from head before raising the head.
- Total time to perform a calibration check is approximately 50 minutes.

B.2 Setup Procedures

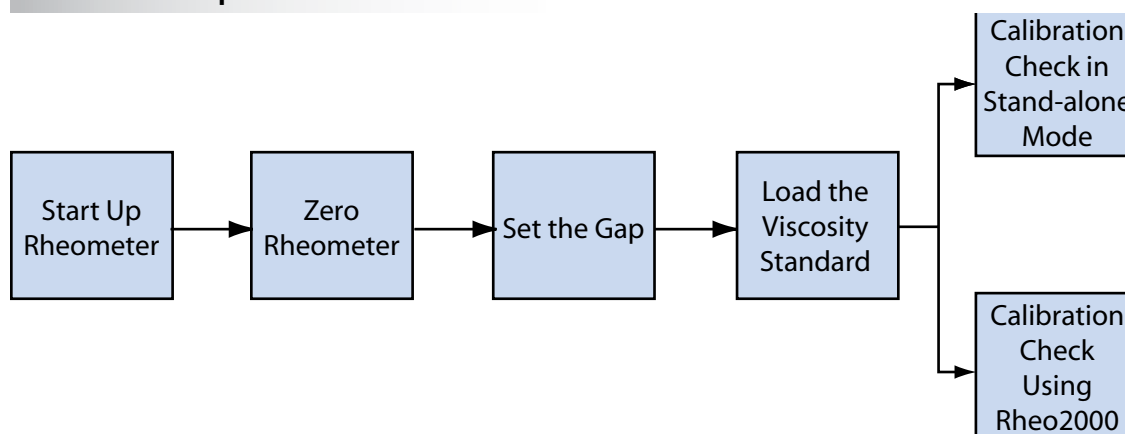

Figure B-1: Flow Chart for Calibration Check Procedure

1. Turn on the R/S+ Rheometer.
2. Turn on the temperature controller. Set the controller to 25°.

¹ Temperature control apparatus consists of one of the following: Peltier System, Water Bath, Oil Bath or Electronic Heat.

² Calibration Check using either an RC25-1 or RC25-2 is not advised.

3. Allow the R/S+ Rheometer to be on for a minimum of 10 minutes prior to taking measurement data or running a zero calibration.
 - Zero Calibration does not have to be executed prior to every test, but should be run no less than once a week.
 - Zero Calibration takes approximately eight (8) minutes.
 - *Best Practice:* run the R/S+ Rheometer at 100 rpm for 30 minutes just prior to zero calibration.
4. Ensure the spindle is not installed on the R/S+ Rheometer.
5. Lower the rheometer head.
6. Lower the spindle coupling collet.

Select the zero calibration option and push the **OK** button.

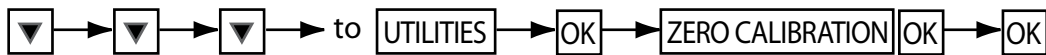

8. Upon successful completion of the zero calibration procedure, the rheometer head will display a message. Press **OK** to save the information. If an error message appears, check the Troubleshooting section of this document. If the problem cannot be fixed, contact Brookfield or an authorized dealer for troubleshooting advice.

B.3 Setting the Gap

1. Raise the rheometer head (handle forward).
2. Attach the designated spindle on the rheometer.
3. Loosen the set screw so the spindle shaft cone moves freely up and down by hand.
4. Lower the rheometer head so spindle and plate are in contact.
5. Allow the spindle to come to temperature.

NOTE: The greater the difference between the test temperature and ambient, the greater the time to come to temperature.

6. Raise the rheometer head.
7. With the rheometer head up, turn the micrometer ring to the zero point. Confirm this by observing the horizontal line on the instrument column and the vertical line on the micrometer ring line up as crosshairs. Turning the micrometer ring clockwise lowers the head; turning the micrometer ring counter-clockwise raises the head.

8. Move the micrometer ring clockwise past zero by one half revolution.
9. Move the micrometer ring counter-clockwise to the zero position and stop there.

NOTE: AFTER THIS STEP, NEVER TURN THE MICROMETER RING CLOCKWISE. A PRECISE GAP SETTING CANNOT BE ASSURED OTHERWISE.

If the micrometer ring IS turned clockwise after this step, the gap setting procedure will need to be repeated starting from Step 7.

10. Lower the rheometer head (by moving the handle away from you) so that the spindle contacts the bottom plate of the rheometer base and the rheometer head is bottomed out on the micrometer ring.
11. Manually turn the outside ring of the dial indicator so that the needle is on zero.

Note: Each division on the dial indicator corresponds to 0.01 mm (or 10 μ m).
12. Move the rheometer head up and down to confirm that the dial indicator needle remains at zero when the rheometer head is in the down (measuring) position.
13. When the following three conditions are met: (1) rheometer head down, (2) micrometer ring set to zero and (3) the dial indicator needle reading zero - tighten the hexagonal nut on the spindle shaft.
14. Raise and lower the rheometer head, to confirm the dial indicator needle reads zero when the rheometer head is in the down (measuring) position.
15. Obtain the spindle truncation from the spindle data sheet that came with the cone spindle.
16. Raise the rheometer head.
17. Turn the micrometer ring counter-clockwise to the truncation point from the spindle data sheet.
18. Lower the rheometer head.

Note: The dial indicator needle will provide visual confirmation of a proper gap setting. For example, a gap setting of 0.05mm will produce a dial indicator reading of 45. A gap setting of 0.04mm will produce a dial indicator reading of 44. A gap setting of 0.06mm will produce a dial indicator reading of 46.

19. Raise and lower the rheometer head to confirm the dial indicator reading remains consistent.

B.4 Loading the Viscosity Standard

1. With the spindle attached and the gap setting confirmed, raise the rheometer head (handle forward).
2. Using a non-metal spatula, place the viscosity standard onto the bottom plate of the rheometer directly below the spindle.

Measuring System (Spindle)	C50-1	C50-2	C75-1	C75-2
Approximate Fluid Volume (mL)	1	2	2.5	5

3. Lower the rheometer head onto the viscosity standard so the dial indicator needle reads the proper gap setting for that spindle.
4. There should be viscosity standard visible around the entire edge of the spindle.
5. Trim excess viscosity standard from the edge using a non-metal spatula:

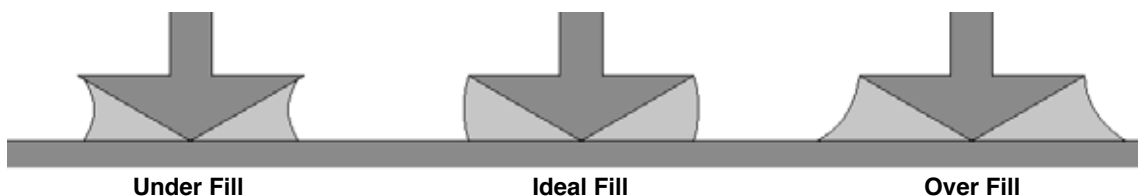

6. Wait fifteen minutes or more to allow the sample to come to temperature.

B.5 Calibration Check Procedure

The R/S+ calibration check can be performed with or without software. If software is not being used, proceed to *B.5.1 Calibration Check in Stand-alone Mode*. If software is being used, proceed to *B.5.2 Calibration Check with RHEO3000 Software*.

B.5.1 Calibration Check in Stand-alone Mode

1. Input Measuring System's Constants
 - a. On the rheometer head, select "Measuring System" within the **Utilities** menu.
 - b. Select the appropriate measuring system.
 - c. Set Tau-prom and K_gamma to value specified on the spindle's measuring system data sheet.

Note: Tau-prom (Kt) is the Shear Stress Factor
K_gamma (Kxxx) is the Shear Rate Factor

- d. Set Distance Dependence to zero.
- e. Save

2. Run Single Program
 - a. Select “Run Single” within the Main-Menu
 - b. Select the appropriate measuring system (e.g. C50-1)
 - c. Select input mode: M[%o.]
 - d. Input steps

Input Value:	
Val. [%o]:	250
Nr. Of Mp:	1
Time [s]:	120

- e. Input ID or leave blank. Press **OK**.
 - f. Press **ST** to start.
 - g. Allow the program to complete.
3. Check the temperature from the RS display (refer to the main manual for this procedure). The temperature should read 25.0°C.
4. Check the viscosity reading. The measured viscosity should fall within the stated viscosity value of the viscosity standard at the appropriate temperature.
5. Repeat Steps 2 through 4 with the torque %o (Val. [%o]:) set to 500 and 750.

B.5.2 Calibration Check with RHEO3000 Software

1. Launch RHEO3000 Software.
2. Enter Measure/Analysis Menu.
3. Select Remote on the R/S front display.
4. Open communication between the rheometer and the PC.
5. Load your Calibration Program. Refer to the RHEO3000 User’s Manual for the block programming procedure. Calibration program parameters should be set up as follows:

Step Nr 1	
Start [%o] :	250
End [%o] :	250
Nr. Of Mp:	40
time [s] :	120

Step Nr 2	
Start [%o] :	500
End [%o] :	500
Nr. Of Mp:	40
time [s] :	120

Step Nr 3	
Start [%o] :	750
End [%o] :	750
Nr. Of Mp:	40
time [s] :	120

6. Enter the following information in the general block data:
 - a. Viscosity Standard Name (e.g. B11000)
 - b. Lot Number
 - c. Expiration Date
 - e. Viscosity Value
 - f. Spindle Serial Number

7. Upon test completion, click the Analysis button. The average viscosity of each step will appear in the bottom window.
8. Average viscosity reading should be within $\pm 5\%$ of the standard's stated viscosity value at the appropriate temperature.

B.5.3 Troubleshooting

Check each of the items below if your measured values fall outside the range of uncertainty:

- a. Assure that the gap is set properly.
- b. Assure that the temperature is set properly.
- c. Assure that correct amount of calibration fluid is present and the gap is filled properly.
- d. Assure that correct spindle constants are being used.
- e. Assure that the rheometer has been zero calibrated.

Error Messages

Message	Cause	Solution
Range Error	User input a value less than the allowed minimum value or greater than the allowed maximum value (Speed or Torque)	Check values. The R/S will advise the maximum and minimum values when this error is displayed.
Zero Cal. Error!	An unacceptable value was measured during the zero point calibration.	Ensure the spindle is not mounted to the R/S. Re-try zero calibration. If this fails, call for service.
ABORT: Speed Max!	Fluid is too thin to be run at requested Shear Stress/Torque level. Alternatively, no fluid is present.	This should not happen following the preceding procedure.

Other Faults

Indication	Possible Cause	Solution
Dial indicator reading is inconsistent.	Set pin has lost hold power.	Pin may need to be replaced. Call for service.
Viscosity reading is low.	Micrometer ring was not lined up with zero on shaft. Head is too high.	Ensure spindle is not mounted to R/S. Re-try zero calibration. If it fails, call for service.
Viscosity reading is low and spindles does not move freely when hex nut is disengaged.	Contamination has entered the gap between the spindle cone piece and spindle shaft.	Loosen set screw. Extend spindle to maximum length. Clean shaft. Repeat if needed. If the spindle cannot be cleaned sufficiently, call for service of spindle.
Viscosity reading is low.	Rheometer has been placed in a drafty location.	Utilize solvent trap; shield unit from drafts.

B.5.4 Flow Diagram for Zero Calibration

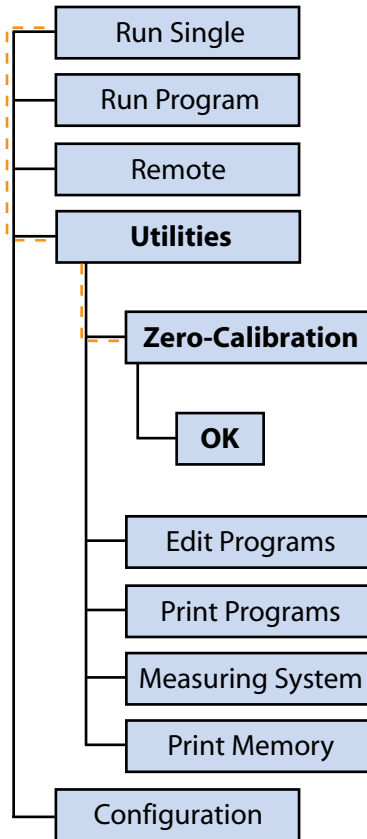

B.5.5 Cone Spindle Data Example



Measuring System Data

Cone/Plate Systems according to DIN 53018

$$\text{Shear Rate} = K_{\gamma} \cdot n$$

$$\text{Shear Stress} = \tau_{\text{prom}} \cdot M$$

K_{γ} (K_{gamma}) = Shear Rate factor (s^{-1}/rpm)

n = rotational speed (RPM)

τ_{prom} (Tau_Prom) = Shear Stress factor ($\text{Pa}/\%$)

M = torque (%)

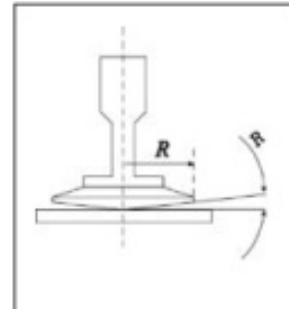

Cone Number:

680

Measuring System	C25-1	C25-2	C50-1	C50-2	C75-1	C75-2
------------------	-------	-------	--------------	-------	-------	-------

Shear Rate Factor (K_{gamma})

5.8312

Shear Stress Factor (Tau_Prom)	12.223	12.223	1.528	1.528	0.4527	0.4527
--	--------	--------	--------------	-------	--------	--------

Sample Volume (mL)	0.08	0.15	0.6	1.2	2	3.9
--------------------	------	------	------------	-----	---	-----

Radius R (mm)	12.5	12.5	25	25	37.5	37.5
---------------	------	------	-----------	----	------	------

Cone Angle α (.)			1.029			
-------------------------	--	--	--------------	--	--	--

Cone Truncation (mm)

0.051

Appendix C: Warranty and Repair Service

Warranty

Brookfield Viscometers are guaranteed for one year from date of purchase against defects in materials and workmanship. They are certified against primary viscosity standards traceable to the National Institute of Standards and Technology (NIST). The Viscometer must be returned to **Brookfield Engineering Laboratories, Inc.** or the Brookfield dealer from whom it was purchased for no charge warranty service. Transportation is at the purchaser's expense. The Viscometer should be shipped in its carrying case together with all spindles originally provided with the instrument.

For repair or service in the **United States**, return to:

Brookfield Engineering Laboratories, Inc.
11 Commerce Boulevard
Middleboro, MA 02346 U.S.A.

Telephone: (508) 946-6200 FAX: (508) 946-6262
<http://www.brookfieldengineering.com>

For repair or service **outside the United States**, consult **Brookfield Engineering Laboratories, Inc.** or the dealer from whom you purchased the instrument.

For repair or service in the **United Kingdom**, return to:

Brookfield Viscometers Limited
1 Whitehall Estate
Flex Meadow
Pinnacles West
Harlow, Essex CM19 5TJ, United Kingdom

Telephone: (44) 27/945 1774 FAX: (44) 27/945 1775
sales@brookfield.co.uk

For repair or service in **Germany**, return to:

Brookfield Engineering Laboratories Vertriebs GmbH
Hauptstrasse 18
D-73547 Lorch, Germany

Telephone: (49) 7172/927100 FAX: (49) 7172/927105
info@brookfield-gmbh.de